



India's No. 1



www.iesacademy.com

IES ACADEMY

Answer Key

Afternoon Session

1st Feb'2015

GATE-2015

Mechanical Engineering



INDIA'S NO.1

www.iesacademy.com

IES ACADEMY

For more details Contact at :

28-B/7-2nd Floor, Jia Sarai, Near IIT, New Delhi-16, E-mail: iesacademy@yahoo.com

Ph.: 011-26537570, 09810958290

Section - I (General Aptitude)

- Q.1 Fill in the blank with the correct idiom/phrase.
That boy from the town was a _____ in the sleepy village.
(a) dog out of herd (b) sheep from the heap
(c) fish out of water (d) bird from the flock

Ans. (C)

End of Solution

- Q.2 Choose the appropriate word/phase, out of the four options given below, to complete the following sentence:
Apparent lifelessness _____ dormant life.
(a) harbours (b) lead to
(c) supports (d) affects

Ans. (A)

End of Solution

- Q.3 Five teams have to compete in a league, with every team playing every other team exactly once, before going to the next round. How many matches will have to be held to complete the league round of matches?
(a) 20 (b) 10
(c) 8 (d) 5

Ans. (B)

End of Solution

- Q.4 Tanya is older than Eric.
Cliff is older than Tanya
Eric is older than Cliff.
If the first two statements are true, then the third statement is:
(a) True (b) False
(c) Uncertain (d) Data insufficient

Ans. (B)

End of Solution

- Q.5 Choose the statement where underlined word is used correctly.
(a) When the teacher eludes to different authors, he is being *elusive*
(b) When the thief keeps eluding the police, he is being *elusive*
(c) Matters that are difficult to understand, identify or remember are *allusive*
(d) Mirages can be *allusive*, but a better way to express them is illusory

Ans. (B)

End of Solution

- Q.6** Select the appropriate option in place of underlined part of the sentence.
Increased productivity necessary reflects greater efforts made by the employees.
- (a) Increase in productivity necessary
(b) Increase productivity is necessary
(c) Increase in productivity necessarily
(d) No improvement required

Ans. (C)

End of Solution

- Q.7** A coin is tossed thrice. Let X be the event that head occurs in each of the first two tosses. Let Y be the event that a tail occurs on the third toss. Let Z be the event that two tails occurs in three tosses. Based on the above information, which one of the following statements is TRUE?
- (a) X and Y are not independent
(b) Y and Z are dependent
(c) Y and Z are independent
(d) X and Z independent

Ans. (B)

End of Solution

- Q.8** Right triangle PQR is to be constructed in the xy – plane so that the right angle is at P and line PR is parallel to the-axis. The x and y coordinates of P , Q , and R are to be integers that satisfy the inequalities:
 $-4 < x < 5$ and $6 < y < 16$. How many different triangles could be constructed with these properties?
- (a) 110
(b) 1,100
(c) 9,900
(d) 10,000

Ans. (C)

End of Solution

- Q.9** In the given figure angle Q is a right angle, $PS:QS = 3:1$, $RT:QT = 5:2$ and $PU:UR = 1:1$. If area of triangle QTS is 20 cm, then the area of triangle PQR in cm^2 is _____.

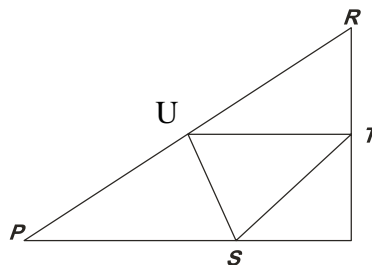

Ans. (280)

End of Solution

Q.10 Given below are two statements followed by two conclusions. Assuming these statements to be true, decide which one logically follows:

Statements:

- I. No manager is a leader.
- II. All leaders are executive.

Conclusions:

- I. No manager is a executive.
- II. All executive is a manager.
- (a) Only conclusion I follows.
- (b) Only conclusion II follows.
- (c) Neither conclusion I nor II follows.
- (d) Both conclusion I and II follow.

Ans. (C)

Section - II (Mechanical Engineering)

Q.1 In the notation $(a/b/c) : (d/e/f)$ for summarizing the characteristics of queueing situation, the letters 'b' and 'd' stand respectively for

- (a) service time distribution and queue discipline
- (b) number of servers and size of calling source
- (c) number of servers and queue discipline
- (d) service time distribution and maximum number allowed in system

Ans. (A)

• • • End of Solution

Q.2 In a machining operation, if the generatrix and directrix both are straight lines, the surface obtained is

- (a) cylindrical
- (b) helical
- (c) plane
- (d) surface of revolution

Ans. (C)

• • • End of Solution

Q.3 In full mould (cavity-less) casting process, the pattern is made of

- (a) expanded polystyrene
- (b) wax
- (c) epoxy
- (d) plaster of Paris

Ans. (A)

• • • End of Solution

Q.4 The lowest eigenvalue of the 2×2 matrix $\begin{pmatrix} 4 & 2 \\ 1 & 3 \end{pmatrix}$ is _____.

Ans. (2)

End of Solution

Q.5 Three parallel pipes connected at the two ends have flow-rates Q_1 , Q_2 and Q_3 respectively, and the corresponding frictional head losses are h_{L1} , h_{L2} and h_{L3} respectively. The correct expressions for total flow rate (Q) and frictional head loss across the two ends (H_L) are

- (a) $Q = Q_1 + Q_2 + Q_3$; $h_L = h_{L1} + h_{L2} + h_{L3}$
- (b) $Q = Q_1 + Q_2 + Q_3$; $h_L = h_{L1} = h_{L2} = h_{L3}$
- (c) $Q = Q_1 = Q_2 = Q_3$; $h_L = h_{L1} + h_{L2} + h_{L3}$
- (d) $Q = Q_1 = Q_2 = Q_3$; $h_L = h_{L1} = h_{L2} = h_{L3}$

Ans. (B)

End of Solution

Q.6 A cylindrical tank with closed ends is filled with compressed air at a pressure of 500 kPa. The inner radius of the tank is 2 m, and it has wall thickness of 10 mm. The magnitude of maximum in-plane shear stress (in MPa) is _____

Ans. (25)

End of Solution

Q.7 The value of $\lim_{x \rightarrow 0} \frac{\sin x}{2 \sin x \cos x}$ is _____.

Ans. (-0.333)

End of Solution

Q.8 For the given fluctuating fatigue load, the values of stress amplitude and stress ratio are respectively

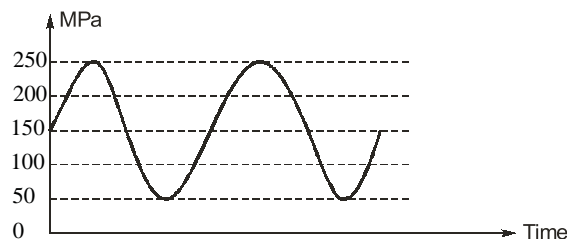

- (a) 100 MPa and 5
- (b) 250 MPa and 5
- (c) 100 MPa and 0.20
- (d) 250 MPa and 0.20

Ans. (A)

End of Solution

- Q.9** A weight of 500 N is supported by two metallic ropes as shown in the figure. The values of tensions T_1 and T_2 are respectively

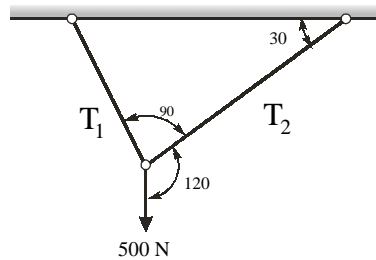

- (a) 433 N and 250 N
(b) 250 N and 433 N
(c) 353.5 N and 250 N
(d) 250 N and 353.5 N

Ans. (A)

End of Solution

- Q.10** An air-standard Diesel cycle consists of the following processes:
1-2 : Air is compressed isentropically.
2-3 : Heat is added at constant pressure.
3-4 : Air expands isentropically to the original volume.
4-1 : Heat is rejected at constant volume
If γ and T denote the specific heat ratio and temperature, respectively, the efficiency of the cycle is

- (a) $1 - \frac{T_4 - T_1}{T_3 - T_2}$
(b) $1 - \frac{T_4 - T_1}{(T_3 - T_2)^\gamma}$
(c) $1 - \frac{(T_4 - T_1)^\gamma}{T_3 - T_2}$
(d) $1 - \frac{T_4 - T_1}{(\gamma)(T_3 - T_2)}$

Ans. (B)

End of Solution

- Q.11** The thermodynamic cycle shown in figure (T - s diagram) indicates

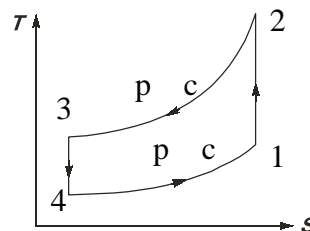

- (a) reversed Carnot cycle
(b) reversed Brayton cycle
(c) vapor compression cycle
(d) vapor absorption cycle

Ans. (B)

End of Solution

- Q.12** Which of the following statements are TRUE for damped vibrations?
- P. For a system having critical damping, the value of damping ratio is unity and system does not undergo a vibratory motion.
- Q. Logarithmic decrement method is used to determine the amount do damping in a physical system.
- R. In case of damping due to dry friction between moving surfaces resisting force of constant magnitude acts opposite to the relative motion.
- S. For the case of viscous damping, drag force is directly proportional to the square of relative velocity.
- (a) *P* and *Q* only
(b) *P* and *S* only
(c) *P*, *Q* and *R* only
(d) *Q* and *S* only

Ans. (C)

End of Solution

- Q.13** If $P(X) = \frac{1}{4}$, $P(Y) = \frac{1}{3}$, and $P(X \cap Y) = \frac{1}{12}$, the value of $P(Y|X)$ is
- (a) $\frac{1}{4}$
(b) $\frac{4}{25}$
(c) $\frac{1}{3}$
(d) $\frac{29}{50}$

Ans. (C)

End of Solution

- Q.14** A gear train is made up of five spur gears as shown in the figure. Gear 2 is driver and gear 6 is driven member. N_2 , N_3 , N_4 , N_5 and N_6 represent number of teeth on gears 2, 3, 5 and 6 respectively. The gear(s) which act(s) as idler(s) is/are

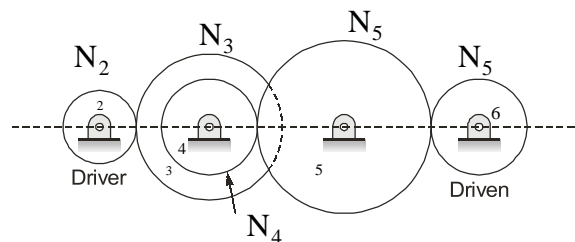

- (a) only 3
(b) only 4
(c) only 5
(d) Both 3 and 5

Ans. (C)

End of Solution

- Q.15** A rigid container of volume 0.5 m^3 contains 1.0 kg of water at 120°C ($v_f = 0.00106 \text{ m}^3/\text{kg}$, $v_g = 0.8908 \text{ m}^3/\text{kg}$). The state of water is
 (a) compressed liquid
 (b) saturated liquid
 (c) a mixture of saturated liquid and saturated vapor
 (d) superheated vapor

Ans. (C)

End of Solution

- Q.16** Using a unit step size, the value of integral $\int_1^2 x \ln x \, dx$ by trapezoidal rule is _____.

Ans. (0.693)

End of Solution

- Q.17** Saturated vapor is condensed to saturated liquid in a condenser. The heat capacity ratio is $C_r = \frac{C_{\min}}{C_{\max}}$. The effectiveness () of the condenser is

- (a) $\frac{1 - \exp[-NTU(1 - C_r)]}{1 - C_r}$ (b) $\frac{1 - \exp[-NTU(1 - C_r)]}{1 - C_r[1 - \exp(-NTU)]}$
 (c) $\frac{NTU}{1 - \exp(-NTU)}$ (d) $1 - \exp(-NTU)$

Ans. (D)

End of Solution

- Q.18** In the figure, link 2 rotates with constant angular velocity ω_2 . A slider link 3 moves outwards with a constant relative velocity $V_{Q/P}$, where Q is a point on slider 3 and P is a point on link 2. The magnitude and direction of Coriolis component of acceleration is given by

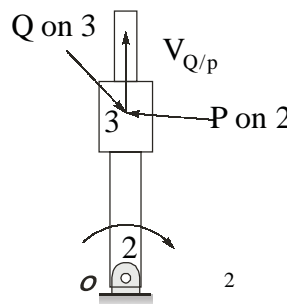

- (a) $2 \cdot V_{Q/P}$; direction of $V_{Q/P}$ rotated by 90° in the direction z
 (b) $\frac{1}{2} V_{Q/P}$; direction of $V_{Q/P}$ rotated by 90° in the direction z
 (c) $2 \cdot V_{Q/P}$; direction of $V_{Q/P}$ rotated by 90° opposite to the direction of z
 (d) $\frac{1}{2} V_{Q/P}$; direction of $V_{Q/P}$ rotated by 90° opposite to the direction z

Ans. (A)

• • • End of Solution

Q.19 Let ϕ be an arbitrary smooth real valued scalar function and V be an arbitrary smooth vector valued function in a three-dimensional space. Which one of the following is an identity?

- (a) $\text{Curl}(\nabla \phi) = \text{Div} V$ (b) $\text{Div} V = 0$
 (c) $\text{Div} \text{Curl} V = 0$ (d) $\text{Div} (\nabla \phi) = \text{Div} V$

Ans. (C)

• • • End of Solution

Q.20 Which two of the following joining processes are autogenous?

- i. Diffusion welding
 ii. Electroslag welding
 iii. Tungsten inert gas welding
 iv. Friction welding
 (a) i and iv (b) ii and iii
 (c) ii and iv (d) i and iii

Ans. (A)

• • • End of Solution

Q.21 The strain hardening exponent n of stainless steel SS 304 with distinct yield and UTS values undergoing plastic deformation is

- (a) $n < 0$ (b) $n = 0$
 (c) $0 < n < 1$ (d) $n = 1$

Ans. (C)

• • • End of Solution

Q.22 The ratio of momentum diffusivity (ν) to thermal diffusivity (α), is called

- (a) Prandtl number (b) Nusselt number
 (c) Biot number (d) Lewis number

Ans. (A)

• • • End of Solution

Q.23 A drill is positioned at point P and its has to proceed to point Q . The coordinates of point Q in the incremental system of defining position of a point in CNC part program will be

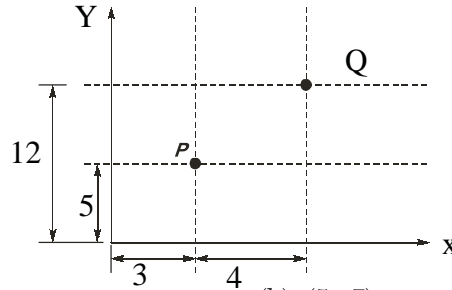

- (a) (3, 12)
- (b) (5, 7)
- (c) (7, 12)
- (d) (4, 7)

Ans. (D)

••• End of Solution

Q.24 For the same material and the mass, which of the following configurations of flywheel will have maximum mass moment of inertia about the axis of rotation OO' passing through the center of gravity.

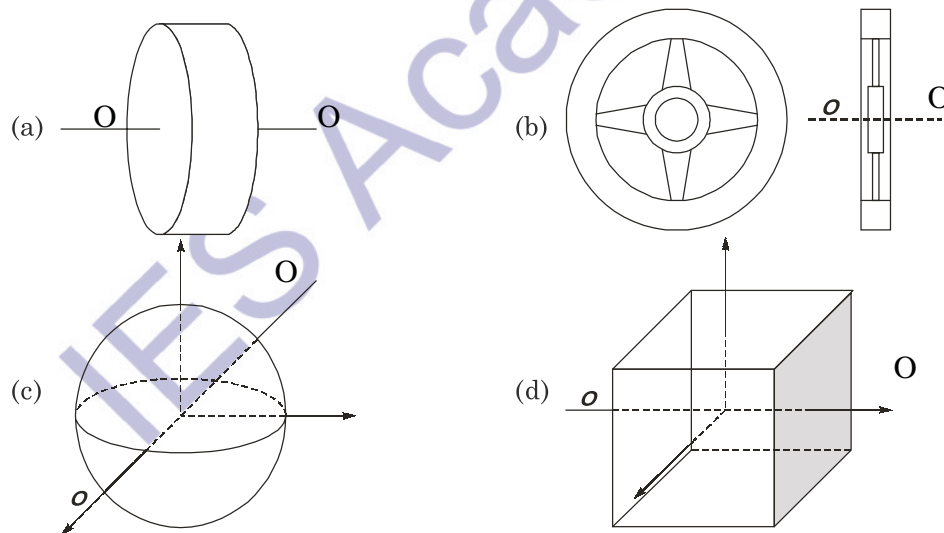

Ans. (B)

••• End of Solution

Q.25 Couette flow is characterized by
 (a) steady, incompressible, laminar flow through a straight circular pipe
 (b) fully developed turbulent flow through a straight circular pipe
 (c) steady, incompressible, laminar flow between two fixed parallel plates
 (d) steady, incompressible, laminar flow between one fixed plate and the other moving with a constant velocity

Ans. (D)

••• End of Solution

- Q.26** Figure shows a single degree of freedom system. The system consists of a massless rigid bar OP hinged at O and a mass m at end P . The natural frequency of vibration of the system is

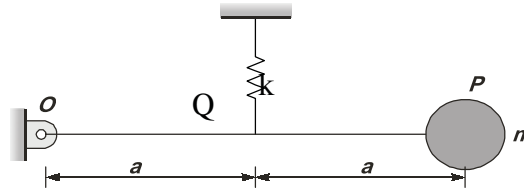

- (a) $f_n = \frac{1}{2} \sqrt{\frac{k}{4m}}$ (b) $f_n = \frac{1}{2} \sqrt{\frac{k}{2m}}$
 (c) $f_n = \frac{1}{2} \sqrt{\frac{k}{m}}$ (d) $f_n = \frac{1}{2} \sqrt{\frac{2k}{m}}$

Ans. (A)

End of Solution

- Q.27** For the overhanging beam shown in figure, the magnitude of maximum bending moment (in kN-m) is _____.

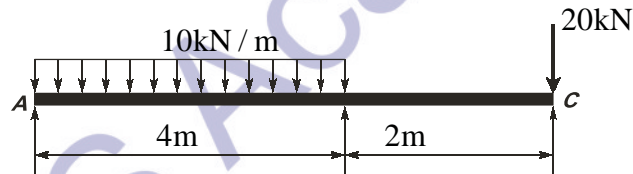

Ans. (40)

End of Solution

- Q.28** A bullet spins as the shot is fired from a gun. For this purpose, two helical slots as shown in the figure are cut in the barrel. Projections A and B on the bullet engage in each of the slots.

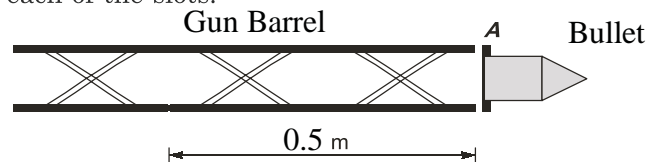

Helical slots are such that one turn of helix is completed over a distance of 0.5 m. If velocity of bullet when it exits the barrel is 20 m/s, its spinning speed in rad/s is _____.

Ans. (251.3274)

End of Solution

- Q.29** A solid sphere 1 of radius ' r ' is placed inside a hollow, closed hemispherical surface 2 of radius ' $4r$ '. The shape factor F_{2-1} is

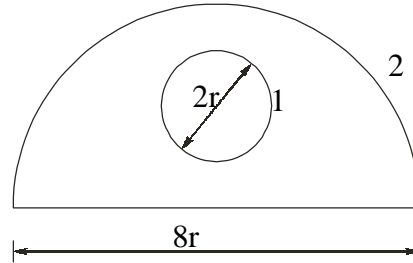

- (a) $\frac{1}{12}$ (b) $\frac{1}{2}$
(c) 2 (d) 12

Ans. (A)

End of Solution

- Q.30** Which of the following statements are TRUE, when the cavitation parameter = 0?

- i. the local pressure is reduced to vapor pressure
ii. cavitation starts
iii. boiling of liquid starts
iv. cavitation stops
(a) i, ii and iv (b) only ii and iii
(c) only i and iii (d) i, ii and iii

Ans. (B)

End of Solution

- Q.31** The torque (in N-m) exerted on the crank shaft of a two stroke engine can be described as $T = 10000 + 1000 \sin 1 - 1200 \cos 2$, where is the crank angle as measured from inner dead center position. Assuming the resisting torque to be constant, the power (in kW) developed by the engine at 100 rpm is _____.

Ans. (104.7197)

End of Solution

- Q.32** Ratio of solidification time of a cylindrical casting (height = radius) of that of a cubic casting of side two times the height of cylindrical casting is _____.

Ans. (0.5625)

End of Solution

Q.33 A Prandtl tube (Pitot-static tube with $C = 1$) is used to measure the velocity of water. The differential manometer reading is 10 mm of liquid column with a relative density of 10. Assuming $g = 9.8 \text{ m/s}^2$, the velocity of water (in m/s) is _____.

Ans. (1.3288)

• • • End of Solution

Q.34 A brick wall $k = 0.9 \frac{\text{W}}{\text{m.K}}$ of thickness 0.18 m separates the warm air in a room from the cold ambient air. On a particular winter day, the outside air temperature is -5°C and the room needs to be maintained at 27°C . The heat transfer coefficient associated with outside air is $20 \frac{\text{W}}{\text{m}^2\text{K}}$. Neglecting the convective resistance of the air inside the room, the heat loss, in $\frac{\text{W}}{\text{m}^2}$, is

(a) 88 (b) 110
(c) 128 (d) 160

Ans. (C)

• • • End of Solution

Q.35 Figure shows a wheel rotating about O_2 . Two points A and B located along the radius of wheel have speeds of 80 m/s and 140 m/s respectively. The distance between the points A and B is 300 mm. The diameter of the wheel (in mm) is _____

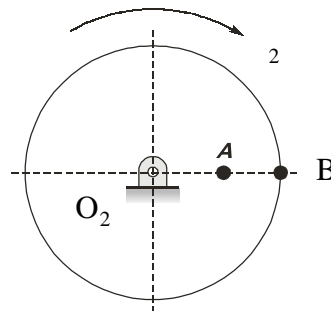

Ans. (1400)

• • • End of Solution

Q.36 Laplace transform of the function $f(t)$ is given by $F(s) = \int_0^\infty f(t)e^{-st} dt$.
Laplace transform of the function shown below is given by

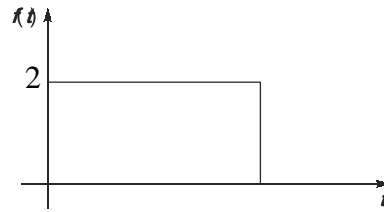

(a) $\frac{1}{s} e^{2s}$

(b) $\frac{1}{2s} e^s$

(c) $\frac{2}{s} 2e^s$

(d) $\frac{1}{s} 2e^s$

Ans. (C)

End of Solution

Q.37 A shaft of length 90 mm has a tapered portion of length 55 mm. The diameter of the taper is 80 mm at one end and 65 mm at the other. If the taper is made by tailstock set over method, the taper angle and the set over respectively are

(a) 15°32' and 12.16 mm

(b) 15°32' and 15.66 mm

(c) 11°22' and 10.26 mm

(d) 10°32' and 14.46 mm

Ans. (A)

End of Solution

Q.38 In a rolling operation using rolls of diameter 500 mm if a 25 mm thick plate cannot be reduced to less than 20 mm in one pass, the coefficient of friction between the roll and the plate is _____.

Ans. (0.1414)

End of Solution

Q.39 A cantilever bracket is bolted to a column using three M12 × 1.75 bolts, P, Q and R. The value of maximum shear stress developed in the bolt P (in MPa) is _____.

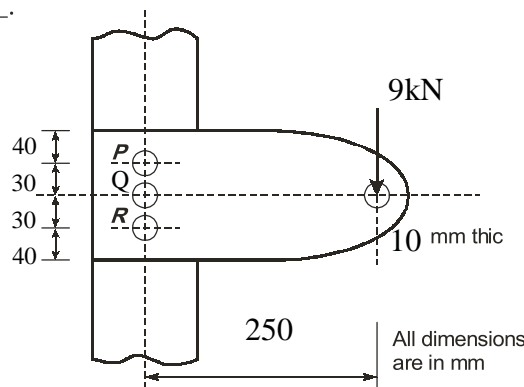

Ans. (332.6321)

End of Solution

Q.40 The value of moment of inertia of the section shown in the figure about the axis-XX is

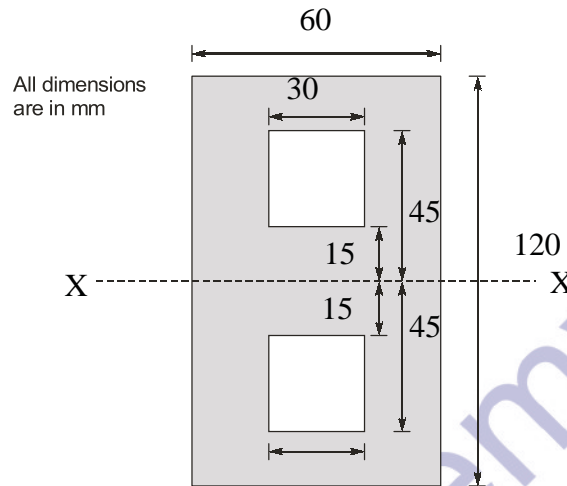

- (a) $8.5050 \times 10^6 \text{ mm}^4$ (b) $6.8850 \times 10^6 \text{ mm}^4$
(c) $7.7625 \times 10^6 \text{ mm}^4$ (d) $8.5725 \times 10^6 \text{ mm}^4$

Ans. (B)

End of Solution

Q.41 Refrigerant vapor enters into the compressor of a standard vapor compression cycle at -10°C ($h = 402 \text{ kJ/kg}$) and leaves the compression at 50°C ($h = 432 \text{ kJ/kg}$). It leaves the condenser at 30°C ($h = 237 \text{ kJ/kg}$). The COP of the cycle is _____.

Ans. (5.5)

End of Solution

Q.42 The number of degrees of freedom of the linkage shown in the figure is

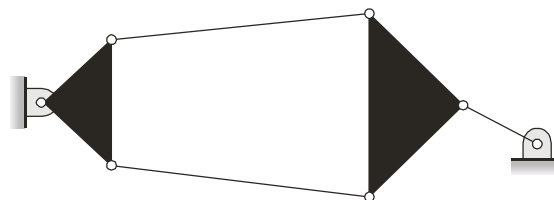

- (a) - 3 (b) 0
(c) 1 (d) 2

Ans. (C)

End of Solution

- Q.43** In a CNC milling operation, the tool has to machine the circular arc from point (20, 20) to (10, 10) at sequence number 5 of the CNC part program. If the center of the arc is at (20, 10) and the machine has incremental mode of defining position coordinates, the correct tool path command is
- (a) N 05 G 90 G01 X-10 Y-10 R10
 - (b) N 05 G 91 G03 X-10 Y-10 R10
 - (c) N 05 G 90 G03 X20 Y20 R10
 - (d) N 05 G 91 G02 X20 Y20 R10

Ans. (B)

End of Solution

- Q.44** The dimensions of a cylindrical side riser (height = diameter) for a 25 cm × 15 cm × 5 cm steel casting are to be determined. For the tabulated shape factor values given below, diameter of the riser (in cm) is _____.

Shape Factor	2	4	6	8	10	12
Riser volume / Casting volume	1.0	0.70	0.55	0.50	0.40	0.35

Ans. (10.6)

End of Solution

- Q.45** Air in a room is at 35° and 60% relative humidity (RH). The pressure in the room is 0.1 MPa. The saturation pressure of water at 35°C is 5.63 kPa. The humidity ratio of the air (in gram/kg of dry air) is _____.

Ans. (21.7457)

End of Solution

- Q.46** For the linear programming problem:

$$\begin{aligned} \text{Maximize } Z &= 3X_1 + 2X_2 \\ \text{Subject to} \\ -2X_1 + 3X_2 &\leq 9 \\ X_1 - 5X_2 &\leq -20 \\ X_1, X_2 &\geq 0 \end{aligned}$$

The above problem has

- (a) unbounded solution
- (b) infeasible solution
- (c) alternative optimum solution
- (d) degenerate solution

Ans. (A)

End of Solution

Q.47 Steam enters a turbine at 30 bar, 300°C ($u = 2750$ kJ/kg, $h = 2993$ kJ/kg) and exits the turbine as saturated liquid at 15 kPa ($u = 225$ kJ/kg, $h = 226$ kJ/kg). Heat loss to the surrounding is 50 kJ/kg of steam flowing through the turbine. Neglecting changes in kinetic energy and potential energy, the work output of the turbine (in kJ/kg of steam) is _____.

Ans. (2717)

• • • End of Solution

Q.48 For ball bearings, the fatigue life L measured in number of revolutions and the radial load F are related by $FL^{1/3} = K$, where K is a constant. It withstands a radial load of 2 kN for a life of 540 million revolutions. The load (in kN) for a life of one million revolutions is _____.

Ans. (16.2865)

• • • End of Solution

Q.49 Orthogonal turning of a mild steel tube with a tool of rake angle 10° carried out at a feed of 0.14 mm/rev. If the thickness of the chip produced is 0.28 mm, the values of shear angle and shear strain will be respectively
(a) $28^\circ 20'$ and 2.19 (b) $22^\circ 20'$ and 3.53
(c) $24^\circ 30'$ and 3.53 (d) $37^\circ 20'$ and 5.19

Ans. (A)

• • • End of Solution

Q.50 A mixture of ideal gases has the following composition by mass:

N_2	O_2	CO_2
60%	30%	10%

If the universal gas constant is 8314 J/kmol-K, the characteristic gas constant of the mixture (in J/kg-K) is _____.

Ans. (274.9963)

• • • End of Solution

Q.51 Newton-Raphson method is used to find the roots of the equation, $x^3 + 2x^2 + 3x - 1 = 0$. If the initial guess is $x_0 = 1$, then the value of x after 2nd iteration is _____.

Ans. (0.3043)

• • • End of Solution

Q.52 The value of

$\int_C [(3x - 8y^2)dx + (4y - 6xy)dy]$, (where C is the boundary of the region boundary by $x = 0$, $y = 0$ and $x + y = 1$) is _____.

Ans. (1.666)

● ● ● End of Solution

Q.53 The annual requirement of rivets at a ship manufacturing company is 2000 kg. The rivets are supplied in units of 1 kg costing Rs. 25 each. If the costs Rs. 100 to place an order and the annual cost of carrying one unit is 9% of its purchase cost, the cycle length of the order (in days) will be_____.

Ans. (76.948 days)

● ● ● End of Solution

Q.54 One side of a wall is maintained at 400 K and the other at 300 K. The rate of heat transfer through the wall is 1000 W and the surrounding temperature is 25°C. Assuming no generation of heat within the wall, the irreversibility (in W) due to heat transfer through the wall is _____.

Ans. (248.333)

● ● ● End of Solution

Q.55 For given matrix $P = \begin{bmatrix} 4 & 3i & i \\ i & 4 & 3i \end{bmatrix}$ where $i = \sqrt{-1}$, the inverse of matrix P

is

(a) $\frac{1}{24} \begin{bmatrix} 4 & 3i & i \\ i & 4 & 3i \end{bmatrix}$

(b) $\frac{1}{25} \begin{bmatrix} i & 4 & i \\ 4 & 3i & i \end{bmatrix}$

(c) $\frac{1}{24} \begin{bmatrix} 4 & 3i & i \\ i & 3 & i \end{bmatrix}$

(d) $\frac{1}{25} \begin{bmatrix} 4 & 3i & i \\ i & 4 & 3i \end{bmatrix}$

Ans. (A)

● ● ● End of Solution

□ □ □ □