



India's No. 1



[www.iesacademy.com](http://www.iesacademy.com)

# IES ACADEMY

## Answer Key

Forenoon Session

7th Feb'2015

# GATE-2015

## Electrical Engineering



INDIA'S NO.1

[www.iesacademy.com](http://www.iesacademy.com)

# IES ACADEMY

For more details Contact at :

28-B/7-2nd Floor, Jia Sarai, Near IIT, New Delhi-16, E-mail: [iesacademy@yahoo.com](mailto:iesacademy@yahoo.com)

Ph.: 011-26537570, 09810958290

**Section - I (General Aptitude)**

- Q.1** Which one of the following combinations is incorrect?
- (a) Acquiescence - Submission
  - (b) Wheedle - Roundabout
  - (c) Flippancy - Lightness
  - (d) Profligate - Extravagant

**Ans. (b)**

---

• • • **End of Solution**

- Q.2** Didn't you buy \_\_\_\_\_ when you went shopping?
- (a) any paper
  - (b) much paper
  - (c) no paper
  - (d) a few paper

**Ans. (a)**

---

• • • **End of Solution**

- Q.3** Base on the given statements, select the most appropriate option to solve the given question.  
If two floors in a certain building are 9 feet apart, how many steps are there in a set of stairs that extends from the first floor to the second floor of the building?  
Statements:  
(I) Each step is  $\frac{3}{4}$  foot high.  
(II) Each step is 1 foot wide.
- (a) Statement I alone is sufficient, but statement II alone is not sufficient.
  - (b) Statement II alone is sufficient, but statement I alone is not sufficient.
  - (c) Both statements together are sufficient, but neither statement alone is sufficient.
  - (d) Statement I and II together are not sufficient.

**Ans. (a)**

---

• • • **End of Solution**

- Q.4** Given Set A = {2, 3, 4, 5} Set B = {11, 12, 13, 14, 15}, two numbers are randomly selected, one from each set. What is the probability that the sum of the two numbers are equals 16?
- (a) 0.20
  - (b) 0.25
  - (c) 0.30
  - (d) 0.33

**Ans. (a)**

---

• • • **End of Solution**

- Q.5** Which of the following options is the closest in meaning to the sentence below?  
She enjoyed herself immensely at the party.
- (a) She had a terrible time at the party
  - (b) She had a horrible time at the party
  - (c) She had a terrific time at the party
  - (d) She had a terrifying time at the party

Ans. (c)

● ● ● End of Solution

- Q.6** The pie chart below has the breakup of the number of students from different departments in an engineering college for the year 2012. The proportion of male to female students in each department is 5 : 4. There are 40 males in Electrical Engineering. What is the difference between the numbers of female students in the Civil department and the female students in the Mechanical department?

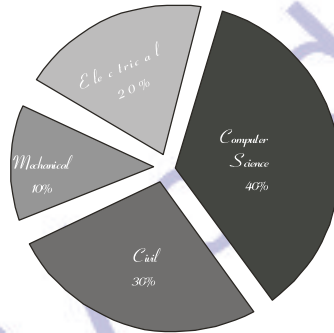

Ans. (32)

● ● ● End of Solution

- Q.7** The probabilities that a student passes in Mathematics, Physics and Chemistry are  $m$ ,  $p$ , and  $c$  respectively. Of these subjects, the student has 75% chance of passing in at least one, a 50% chance of passing in at least two and a 40% chance of passing in exactly two. Following relations are drawn in  $m$ ,  $p$ ,  $c$ :
- (I)  $p + m + c = 27/20$
  - (II)  $p + m + c = 13/20$
  - (III)  $(p) \times (m) \times (c) = 1/10$
- (a) Only relation I is true
  - (b) Only relation II is true
  - (c) Relations II and III are true
  - (d) Relations I and III are true

Ans. (d)

● ● ● End of Solution

- Q.8** The number of students in a class who have answered correctly, wrongly, or not attempted each question in an exam, are listed in the table below. The marks for each question are also listed. There is no negative or partial marking

Q No	Marks	Answered correctly	Answered Wrongly	Not Attempted
1	2	21	17	6
2	3	15	27	2
3	1	#	29	4
4	2	23	18	3
5	5	31	12	1

What is the average of the marks obtained by the class in the examination?

- (a) 2.290 (b) 2.970  
(c) 6.795 (d) 8.795

Ans. (c)

End of Solution

**Q.9** Select the alternative meaning of the underlined part of the sentence.

The chain snatchers took to their heels when the police party arrived.

- (a) took shelter in a thick jungle (b) open indiscriminate fire  
(c) took to flight (d) unconditionally surrendered

Ans. (c)

End of Solution

**Q.10** The given statement is followed by some courses of action. Assuming the statement to be true, decide the correct option.

Statement:

There has been a significant drop in the water level in the lakes supplying water to the city.

Course of action:

- (I) The water supply authority should impose a partial cut in supply to tackle the situation.  
(II) The government should appeal to the all the residents through mass media for minimal use of water.  
(III) The government should ban the water supply in lower areas.  
(a) Statements I and II follow. (b) Statements I and III follow.  
(c) Statements II and III follow. (d) All statements follow.

Ans. (a)

End of Solution

Section - II (Electrical Engineering)

Q.1 The impulse response  $g(t)$  of a system,  $G$ , is as shown in figure (a). What is the maximum value attained by the impulse response of two cascaded blocks of  $G$  as shown in figure (b)?

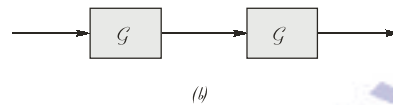
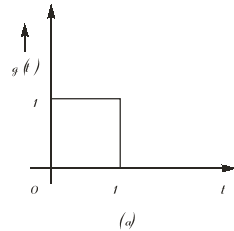

(a)  $\frac{2}{3}$

(b)  $\frac{3}{4}$

(c)  $\frac{4}{5}$

(d) 1

Ans. (d)

End of Solution

Q.2 If the sum of the diagonal elements of a  $2 \times 2$  matrix is  $-6$ , then the maximum possible value of determinant of the matrix is \_\_\_\_\_

Ans. (9)

End of Solution

Q.3 An inductor is connected in parallel with a capacitor as shown in the figure.

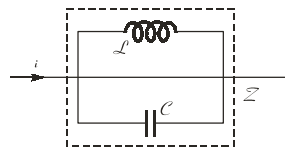

As the frequency of current  $i$  is increased, the impedance ( $Z$ ) of the network varies as

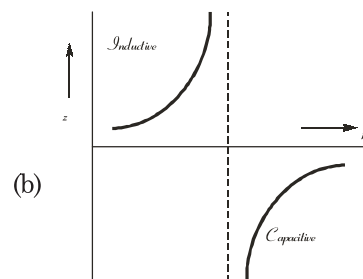
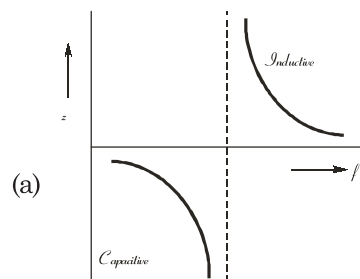

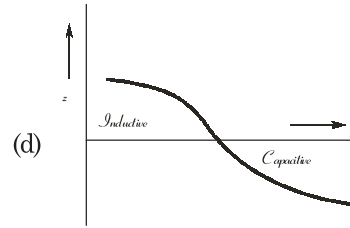
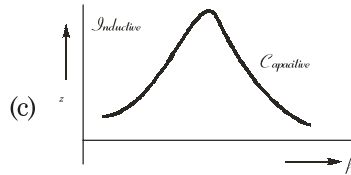

Ans. (b)

End of Solution

Q.4 Base load power plants are

P. wind farms

Q. run-of-river plants

R. nuclear power plants

S. diesel power plants

(a) P, Q and S only

(b) P, R and S only

(c) P, Q and R only

(d) Q and R only

Ans. (d)

End of Solution

Q.5 If a continuous function  $f(x)$  does not have a root in the interval  $[a, b]$ , then which one of the following statements is TRUE?

(a)  $f(a) f(b) = 0$

(b)  $f(a) f(b) < 0$

(c)  $f(a) f(b) > 0$

(d)  $f(a)f(b) = 0$

Ans. (c)

End of Solution

Q.6 A separately excited DC generator has an armature resistance of  $0.1 \Omega$  and negligible armature inductance. At rated field current and rated rotor speed, its open-circuit voltage is 200 V. When this generator is operated at half the rated speed, with half the rated field current, an un-charged  $1000 \mu\text{F}$  capacitor is suddenly connected across the armature terminals. Assume that the speed remains unchanged during the transient. At what time (in microsecond) after the capacitor is connected with the voltage across it reach 25 V?

(a) 62.25

(b) 69.3

(c) 73.25

(d) 77.3

Ans. (b)

End of Solution

Q.7 A (0- 50 A) moving coil ammeter has a voltage drop of 0.1 V across its terminals at full scale deflection. The external shunt resistance (in milliohms) needed to extend its range to (0 - 500 A) is \_\_\_\_\_.

Ans. (0.22)

End of Solution

Q.8 Consider a function  $\vec{f} = \frac{1}{r^2} \hat{r}$ , where  $r$  is the distance from the origin and  $\hat{r}$  is the unit vector in the radial direction. The divergence of this function over a sphere of radius  $R$ , which includes the origin, is

- (a) 0 (b) 2  
(c) 4 (d)  $R$

Ans. (a)

End of Solution

Q.9 A random variable  $X$  has probability density function  $f(x)$  as given below:

$$f(x) = \begin{cases} a - bx & \text{for } 0 \leq x \leq 1 \\ 0 & \text{otherwise} \end{cases}$$

If the expected value  $E[X] = 2/3$ , then  $Pr[X < 0.5]$  is \_\_\_\_\_.

Ans. (0.25)

End of Solution

Q.10 Consider a one-turn rectangular loop of wire placed in a uniform magnetic field as shown in the figure. The plane of the loop is perpendicular to the field lines. The resistance of the loop is  $0.4 \Omega$ , and its inductance is negligible. The magnetic flux density (in Tesla) is a function of time, and is given by  $B(t) = 0.25 \sin t$ , where  $\omega = 2 \times 50$  radian/second. The power absorbed (in Watt) by the loop from the magnetic field is \_\_\_\_\_.

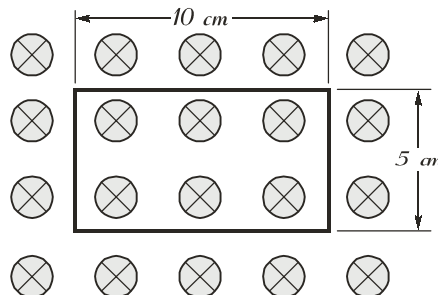

Ans. (0.061)

End of Solution

Q.11 In the  $4 \times 1$  multiplexer, the output  $F$  is given by  $F = A \oplus B$ . Find the required input  $I_3 I_2 I_1 I_0$

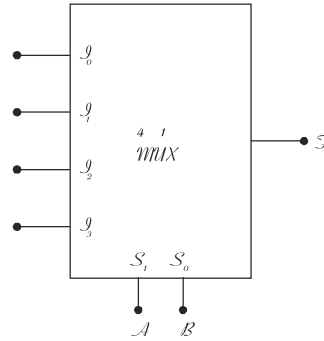

- (a) 1010
- (b) 0110
- (c) 1000
- (d) 1110

Ans. (b)

End of Solution

Q.12 In the following chopper, the duty ratio of switch  $S$  is 0.4. If the inductor and capacitor are sufficiently large to ensure continuous inductor current and ripple free capacitor voltage, the charging current (in Ampere) of the 5 V battery, under steady-state, is \_\_\_\_\_.

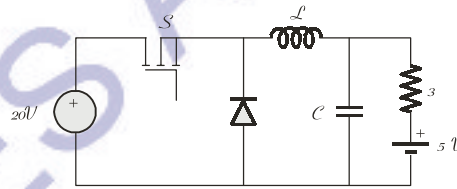

Ans. (1)

End of Solution

Q.13 For the signal-flow graph shown in the figure, which one of the following expressions

is equal to the transfer function  $\frac{Y(s)}{X_2(s)} \Big|_{X_1(s)=0}$  ?

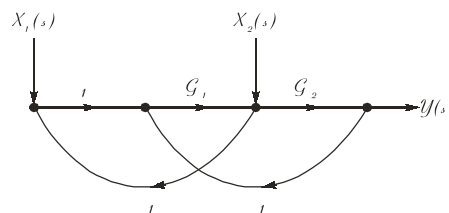



(a)  $\frac{G_1}{1 + G_2(1 + G_1)}$

(b)  $\frac{G_2}{1 + G_1(1 + G_2)}$

(c)  $\frac{G_1}{1 + G_1G_2}$

(d)  $\frac{G_2}{1 + G_1G_2}$

Ans. (b)

End of Solution

Q.14 In the given circuit, the silicon transistor has  $\beta = 75$  and a collector voltage  $V_C = 9$  V. Then the ratio of  $R_B$  and  $R_C$  is

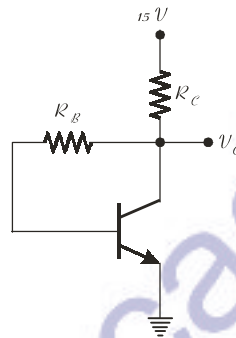

Ans. (105.14)

End of Solution

Q.15 The self inductance of the primary winding of a single phase, 50 Hz, transformer is 800 mH, and that of the secondary winding is 600 mH. The mutual inductance between these two windings is 480 mH. The secondary winding of this transformer is short circuited and the primary winding is connected to a 50 Hz, single phase, sinusoidal voltage source. The current flowing in both the windings is less than their respective rated currents. The resistance of both windings can be neglected. In this condition, what is the effective inductance (in mH) seen by the source?

(a) 416

(b) 440

(c) 200

(d) 920

Ans. (a)

End of Solution

Q.16 Of the four characteristics given below, which are the major requirements for an instrumentation amplifier?

P. High common mode rejection ratio

Q. High input impedance

R. High linearity

S. High output impedance

- (a) P, Q and R only  
(b) P and R only  
(c) P, Q and S only  
(d) Q, R and S only

Ans. (a)

End of Solution

- Q.17** When the Wheatstone bridge shown in the figure is used to find the value of resistor  $R_X$ , the galvanometer  $G$  indicates zero current when  $R_1 = 50$ ,  $R_2 = 65$  and  $R_3 = 100$ . If  $R_3$  is known with 5% tolerance on its nominal value of 100, what is the range of  $R_X$  in Ohms?

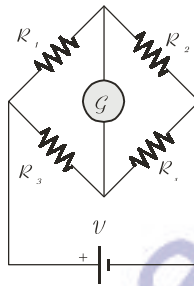

- (a) [123.50, 136.50]  
(b) [125.89, 134.12]  
(c) [117.00, 143.00]  
(d) [120.25, 139.75]

Ans. (a)

End of Solution

- Q.18** For the given circuit, the Thevenin equivalent is to be determined. The Thevenin voltage,  $V_{Th}$  (in Volt), seen from terminal  $AB$  is \_\_\_\_\_.

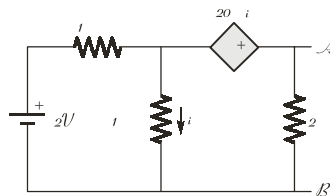

Ans. (3.36)

End of Solution

- Q.19** Consider a HVDC link which uses thyristor based line-commutated converters as shown in the figure. For a power flow of 750 MW from System 1 to System 2, the voltage at the two ends, and the current are given by:  $V_1 = 500$  kV,  $V_2 = 485$  kV and  $I = 1.5$  kA. If the direction of power flow is to be reversed (that is, from

System 2 to System 1) without changing the electrical connections, then which one of the following combinations is feasible?

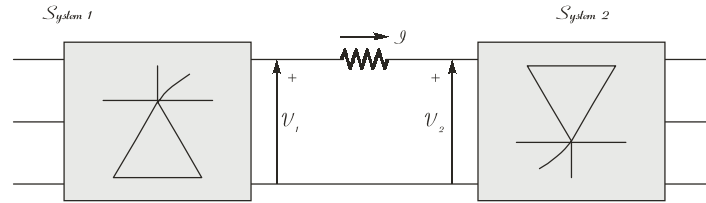

- (a)  $V_1 = -500$  kV,  $V_2 = -485$  kV and  $I = 1.5$  kA
- (b)  $V_1 = -485$  kV,  $V_2 = -500$  kV and  $I = 1.5$  kA
- (c)  $V_1 = 500$  kV,  $V_2 = 485$  kV and  $I = -1.5$  kA
- (d)  $V_1 = -500$  kV,  $V_2 = -485$  kV and  $I = -1.5$  kA

Ans. (b)

End of Solution

**Q.20** A Bode magnitude plot for the transfer function  $G(s)$  of a plant is shown in the figure. Which one of the following transfer functions best describes the plant?

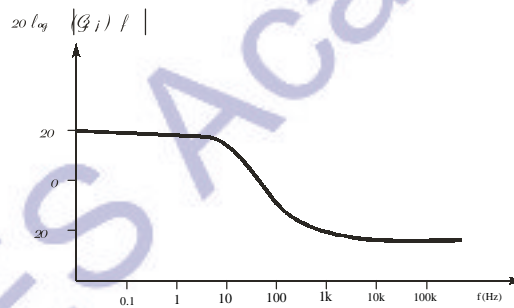

- (a)  $\frac{1000(s + 10)}{s + 1000}$
- (b)  $\frac{10(s + 10)}{s(s + 1000)}$
- (c)  $\frac{s + 1000}{10s(s + 10)}$
- (d)  $\frac{s + 1000}{10(s + 10)}$

Ans. (d)

End of Solution

**Q.21** The primary mmf is least affected by the secondary terminal conditions in a

- (a) power transformer
- (b) potential transformer
- (c) current transformer
- (d) distribution transformer

Ans. (b)

End of Solution

**Q.22** The voltages developed across the 3  $\Omega$  and 2  $\Omega$  resistors shown in the figure are 6 V and 2 V respectively, with the polarity as marked. What is the power (in Watt) delivered by the 5 V voltage source?

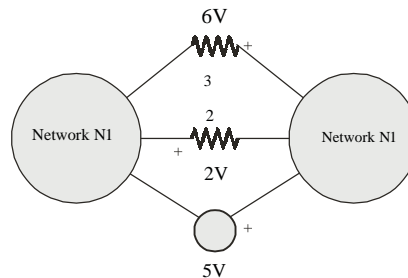

- (a) 5 (b) 7  
(c) 10 (d) 14

Ans. (a)

• • • End of Solution

**Q.23** Consider the circuit shown in the figure. In this circuit  $R = 1 \text{ k}\Omega$ , and  $C = 1 \text{ }\mu\text{F}$ . The input voltage is sinusoidal with a frequency of 50 Hz, represented as a phasor with magnitude  $V_i$  and phase angle 0 radian as shown in the figure. The output voltage is represented as a phasor with magnitude  $V_o$  and phase angle  $\theta$  radian. What is the value of the output phase  $\theta$  (in radian) relative to the phase angle of the input voltage?

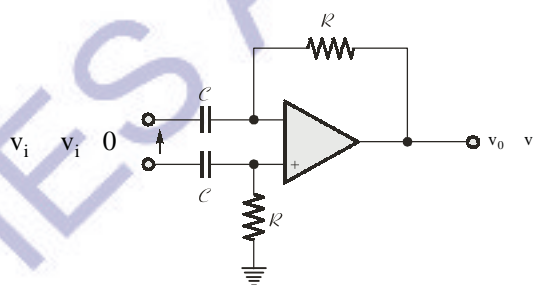

- (a) 0 (b)  $\frac{\pi}{2}$   
(c)  $-\frac{\pi}{2}$  (d)  $-\frac{\pi}{4}$

Ans. (d)

• • • End of Solution

**Q.24** A steady current  $I$  is flowing in the  $-x$  direction through each of two infinitely long wires at  $y = \pm \frac{L}{2}$  as shown in the figure. The permeability of the medium is  $\mu_0$ . The  $B$ -field at  $(0, L, 0)$  is

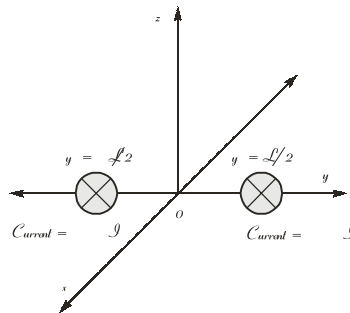

- (a)  $\frac{4}{3} \frac{0I}{L} \hat{z}$                       (b)  $\frac{4}{3} \frac{0I}{L} \hat{z}$   
 (c) 0                                      (d)  $\frac{3}{4} \frac{0I}{L} \hat{z}$

Ans. (a)

• • • End of Solution

**Q.25** A moving average function is given by  $\frac{1}{T} \int_{t-r}^t u(t)dt$ . If the input  $u$  is a sinusoidal signal of frequency  $\frac{1}{2T}$  Hz, then in steady state, the output  $y$  will lag  $u$  (in degree) by \_\_\_\_\_.

Ans. (90)

• • • End of Solution

**Q.26** Two single-phase transformer  $T_1$  and  $T_2$  each rated at 500 kVA are operated in parallel. Percentage impedances of  $T_1$  and  $T_2$  are  $(1 + j6)$  and  $(0.8 + j4.8)$ , respectively. To share a load of 1000 kVA at 0.8 lagging power factor, the contribution of  $T_2$  (in kVA) is \_\_\_\_\_.

Ans. (555.55)

• • • End of Solution

**Q.27** A parallel plate capacitor is partially filled with glass of dielectric constant 4.0 as shown below. The dielectric strengths of air and glass are 30 kV/cm and 300 kV/cm, respectively. The maximum voltage (in kilovolts), which can be applied across the capacitor without any breakdown, is \_\_\_\_\_

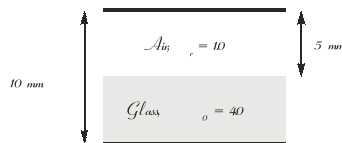

Ans. (37.5)

• • • End of Solution

- Q.28**  $f(A, B, C, D) = M(0, 1, 3, 4, 5, 7, 9, 11, 12, 13, 14, 15)$  is a maxterm representation of Boolean function  $f(A, B, C, D)$  where  $A$  is the MSB and  $D$  is the LSB. The equivalent minimized representation of this function is
- $(A + \bar{C} + D)(\bar{A} + \bar{B} + D)$
  - $A\bar{C}D + \bar{A}BD$
  - $\bar{A}\bar{C}\bar{D} + \bar{A}B\bar{C}\bar{D} + \bar{A}\bar{B}\bar{C}\bar{D}$
  - $(B + \bar{C} + D)(A + \bar{B} + \bar{C} + D)(\bar{A} + \bar{B} + \bar{C} + D)$

Ans. (a)

End of Solution

- Q.29** A 3-phase 50 Hz square wave (6-step) VSI feeds a 3-phase, 4 pole induction motor. The VSI line voltage has a dominant 5<sup>th</sup> harmonic component. If the operating slip of the motor with respect to fundamental component voltage is 0.04, the slip of the motor with respect to 5<sup>th</sup> harmonic component of voltage is \_\_\_\_\_.

Ans. (1.2)

End of Solution

- Q.30** Consider a discrete time signal given by
- $$x[n] = (-0.25)^n u[n] + (0.5)^n u[-n - 1]$$
- The region of convergence of its Z-transform would be
- the region inside the circle of radius 0.5 and centered at origin
  - the region outside the circle of radius 0.25 and centered at origin
  - the annular region between the two circles, both centered at origin and having radii 0.25 and 0.5.
  - the entire Z plane

Ans. (c)

End of Solution

- Q.31** The signum function is given by

$$\text{sgn}(x) = \begin{cases} \frac{x}{|x|} & : x \neq 0 \\ 0 & : x = 0 \end{cases}$$

The Fourier series expansion of  $\text{sgn}(\cos(t))$  has

- only sine terms with all harmonics
- only cosine terms with all harmonics
- only sine terms with even numbered harmonics
- only cosine terms with odd numbered harmonics

Ans. (d)

End of Solution

Q.32 Find the transfer function  $\frac{Y(s)}{X(s)}$  of the system given below

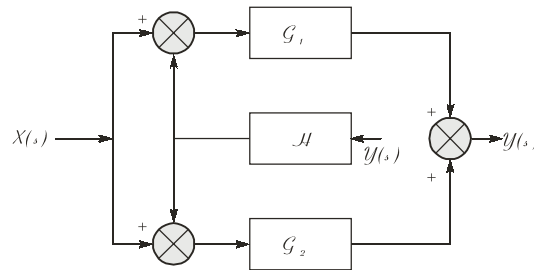

(a)  $\frac{G_1}{1 - HG_1} + \frac{G_2}{1 - HG_2}$

(b)  $\frac{G_1}{1 + HG_1} + \frac{G_2}{1 + HG_2}$

(c)  $\frac{G_1 + G_2}{1 + H(G_1 + G_2)}$

(d)  $\frac{G_1 + G_2}{1 - H(G_1 + G_2)}$

Ans. (c)

End of Solution

Q.33 A 200/400 V, 50 Hz, two-winding transformer is rated at 20 kVA. Its windings are connected as an auto-transformer of rating 200/600 V. A resistive load of 12 is connected to the high voltage (600 V) side of the auto-transformer. The value of equivalent load resistance (in Ohm) as seen from low voltage side is \_\_\_\_\_.

Ans. (1.33)

End of Solution

Q.34 An unbalanced DC Wheatstone bridge is shown in the figure. At what value of  $p$  will the magnitude of  $V_0$  be maximum?

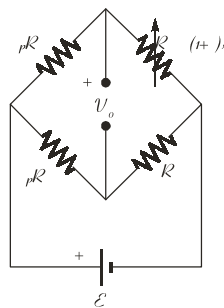

(a)  $\sqrt{1+x}$

(b)  $(1+x)$

(c)  $\frac{1}{\sqrt{1+x}}$

(d)  $\sqrt{1-x}$

Ans. (a)

End of Solution

- Q.35** The single-phase full-bridge voltage source inverter (VSI), shown in figure, has an output frequency of 50 Hz. It uses unipolar pulse width modulation with switching frequency of 50 kHz and modulation index of 0.7. For  $V_{in} = 100$  V DC,  $L = 9.55$  mH,  $C = 63.66$  F, and  $R = 5$  , the amplitude of the fundamental component in the output voltage  $V_o$  (in Volt) under steady-state is \_\_\_\_\_.

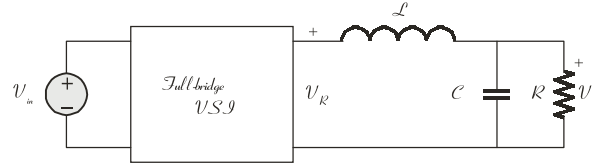

Ans. (49.5)

End of Solution

- Q.36** A DC motor has the following specifications: 10 hp, 37.5 A, 230 V; flux/pole = 0.01 Wb, number of poles = 4, number of conductors = 666, number of parallel paths = 2. Armature resistance = 0.267 . The armature reaction is negligible and rotational losses are 600 W. The motor operates from a 230 V DC supply. If the motor runs at 1000 rpm, the output torque produced (in Nm) is \_\_\_\_\_.

Ans. (57.8)

End of Solution

- Q.37** Two players, A and B, alternately keep rolling a fair dice. The person to get a six first wins the game. Given that player A starts the game, the probability that A wins the game is

- (a)  $\frac{5}{11}$  (b)  $\frac{1}{2}$   
(c)  $\frac{7}{13}$  (d)  $\frac{6}{11}$

Ans. (d)

End of Solution

- Q.38** A 50 Hz generating unit has  $H$ -constant of MJ/MVA. The machine is initially operating in steady state at synchronous speed, and producing 1 pu of real power. The initial value of the rotor angle is  $5^\circ$ , when a bolted three phase to ground short circuit fault occurs at the terminal of the generator. Assuming the input mechanical power to remain at 1 pu, the value of in degrees, 0.02 second after the fault is \_\_\_\_\_.

Ans. (3.79)

End of Solution



**Q.39** Determine the correctness or otherwise of the following Assertion [a] and the Reason [r].

Assertion: Fast decoupled load flow method gives approximate load flow solution because it uses several assumptions.

Reason: Accuracy depends on the power mismatch vector tolerance.

- (a) Both [a] and [r] are true and [r] is the correct reason for [a].
- (b) Both [a] and [r] are true but [r] is not the correct reason for [a].
- (c) Both [a] and [r] are false.
- (d) [a] is false and [r] is true.

Ans. (d)

End of Solution

**Q.40** The op-amp shown in the figure has a finite gain  $A = 1000$  and an infinite input resistance. A step-voltage  $V_i = 1$  mV is applied at the input at time  $t = 0$  as shown. Assuming that the operational amplifier is not saturated, the time constant (in millisecond) of the output voltage  $V_o$  is

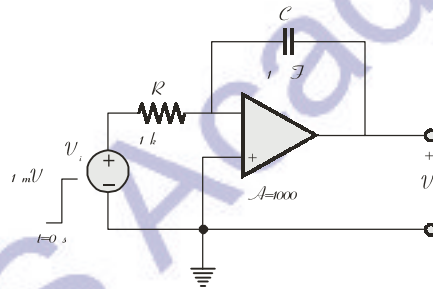

- (a) 1001
- (b) 101
- (c) 11
- (d) 1

Ans. (d)

End of Solution

**Q.41** Consider the economic dispatch problem for a power plant having two generating units. The fuel costs in Rs/MWh along with the generation limits for the two units are given below:

$$C_1(P_1) = 0.01 P_1^2 + 30P_1 + 10 \quad ; \quad 100 \text{ MW} \leq P_1 \leq 150 \text{ MW}$$

$$C_2(P_2) = 0.05 P_2^2 + 10P_2 + 10 \quad ; \quad 100 \text{ MW} \leq P_2 \leq 180 \text{ MW}$$

The incremental cost (in Rs/MWh) of the power plant when it supplies 200 MW is \_\_\_\_\_.

Ans. (4620)

End of Solution

**Q.42** A solution of the ordinary differential equation  $\frac{d^2y}{dt^2} + 5\frac{dy}{dt} + 6y = 0$  is such that  $y(0) = 2$  and  $y(1) = \frac{1 - 3e}{e^3}$ . The value of  $\frac{dy}{dt}(0)$  is \_\_\_\_\_.

Ans. (0)

End of Solution

**Q.43** An 8-bit, unipolar Successive Approximation Register type ADC is used to convert 3.5 V to digital equivalent output. The reference voltage is +5 V. The output of the ADC at the end of 3rd clock pulse after the start of conversion, is  
 (a) 1010 0000 (b) 1000 0000  
 (c) 0000 0001 (d) 0000 0011

Ans. (a)

End of Solution

**Q.44** The figure shows a digital circuit constructed using negative edge triggered J-K flip flops. Assume a starting state of  $Q_2Q_1Q_0 = 000$  will repeat after \_\_\_\_\_ number of cycles of the clock CLK

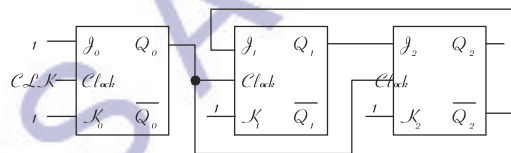

Ans. (3)

End of Solution

**Q.45** A sustained three-phase fault occurs in the power system shown in the figure. The current and voltage phasors during the fault (on a common reference), after the natural transients have died down, are also shown. Where is the fault located?

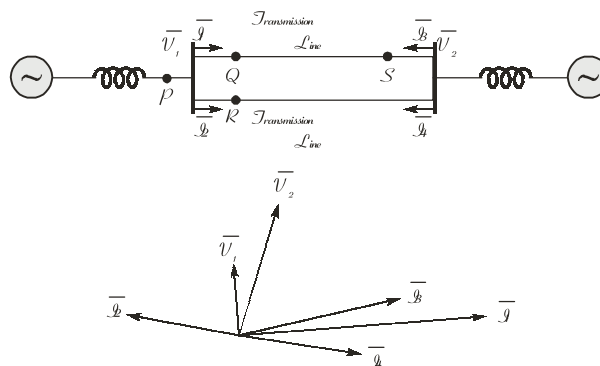

- (a) Location  $P$  (b) Location  $Q$   
(c) Location  $R$  (d) Location  $S$

Ans. (c)

• • • End of Solution

Q.46 The maximum value of " $\alpha$ " such that the matrix  $\begin{matrix} 3 & 0 & 2 \\ 1 & 1 & 0 \\ 0 & \alpha & 2 \end{matrix}$  has three linearly independent real eigenvectors is

- (a)  $\frac{2}{3\sqrt{3}}$  (b)  $\frac{1}{3\sqrt{3}}$   
(c)  $\frac{1+2\sqrt{3}}{3\sqrt{3}}$  (d)  $\frac{1+\sqrt{3}}{3\sqrt{3}}$

Ans. (d)

• • • End of Solution

Q.47 A self commutating switch SW, operated at duty cycle  $\frac{1}{2}$  is used to control the load voltage as shown in the figure.

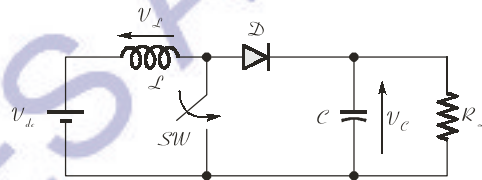

Under steady state operating conditions, the average voltage across the inductor and the capacitor respectively, are

- (a)  $V_L = 0$  and  $V_C = \frac{1}{2} V_{dc}$  (b)  $V_L = \frac{1}{2} V_{dc}$  and  $V_C = \frac{1}{2} V_{dc}$   
(c)  $V_L = 0$  and  $V_C = \frac{1}{2} V_{dc}$  (d)  $V_L = \frac{1}{2} V_{dc}$  and  $V_C = \frac{1}{2} V_{dc}$

Ans. (a)

• • • End of Solution

Q.48 A separately excited DC motor runs at 1000 rpm on no load when its armature terminals are connected at a 200 V DC source and the rated voltage is applied to the field winding. The armature resistance of this motor is  $1 \Omega$ . The no-load armature current is negligible. With the motor developing its full load torque,

the armature voltage is set so that the rotor speed is 500 rpm. When the load torque is reduced to 50% of the full load value under the same armature voltage conditions, the speed rises to 520 rpm. Neglecting the rotational losses, the full load armature current (in Ampere) is \_\_\_\_\_.

Ans. (8)

● ● ● End of Solution

Q.49 In the given circuit, the parameter  $k$  is positive, and the power dissipated in the  $2\ \Omega$  resistor is 12.5 W. The value of  $k$  is \_\_\_\_\_.

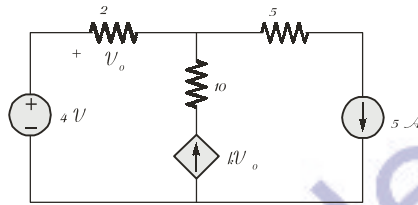

Ans. (0.5)

● ● ● End of Solution

Q.50 The circuit shown is meant to supply a resistive load  $R_L$  from two separate DC voltage sources. The switches  $S_1$  and  $S_2$  are controlled so that only one of them is ON at any instant.  $S_1$  is turned on for 0.2 ms and  $S_2$  is turned on for 0.3 ms in a 0.5 ms switching cycle time period. Assuming continuous conduction of the inductor current and negligible ripple on the capacitor voltage, the output voltage  $V_o$  (in Volt) across  $R_L$  is \_\_\_\_\_.

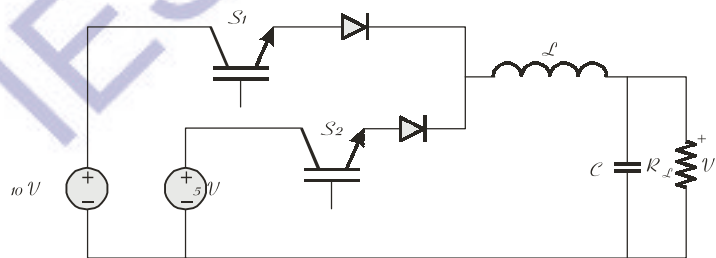

Ans. (7)

● ● ● End of Solution

Q.51 In the signal flow diagram given in the figure,  $u_1$  and  $u_2$  are possible inputs whereas  $y_1$  and  $y_2$  are possible outputs. When would the SISO system derived from this diagram be controllable and observable?

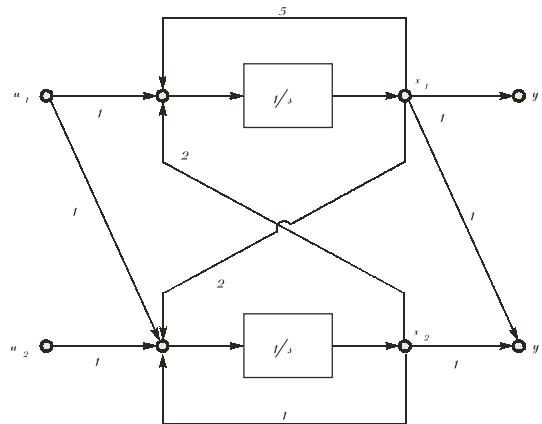

- (a) When  $u_1$  is the only input and  $y_1$  is the only output
- (b) When  $u_2$  is the only input and  $y_1$  is the only output
- (c) When  $u_1$  is the only input and  $y_2$  is the only output
- (d) When  $u_2$  is the only input and  $y_2$  is the only output

Ans. (c)

End of Solution

- Q.52** The transfer function of a second order real system with a perfectly flat magnitude response of unity has a pole at  $(2 - j3)$ . List all the poles and zeros.
- (a) Poles at  $(2 \pm j3)$ , no zeros.
  - (b) Poles at  $(\pm 2 - j3)$ , one zero at origin.
  - (c) Poles at  $(2 - j3)$ ,  $(-2 + j3)$ , zeroes at  $(-2 - j3)$ ,  $(2 + j3)$ .
  - (d) Poles at  $(2 \pm j3)$ , zeros at  $(-2 \pm j3)$ .

Ans. (d)

End of Solution

- Q.53** In a linear two-port network, when 10 V is applied to Port 1, a current of 4 A flows through Port 2 when it is short-circuited. When 5 V is applied to Port 1, a current of 1.25 A flows through a 1  $\Omega$  resistance connected across Port 2. When 3 V is applied to Port 1, the current (in Ampere) through a 2  $\Omega$  resistance connected across Port 2 is \_\_\_\_\_.

Ans. (0.54)

End of Solution

- Q.54** The open loop poles of a third order unity feedback system are at 0, -1, -2. Let the frequency corresponding to the point where the root locus of the system transits to unstable region be K. Now suppose we introduce a zero in the open

loop transfer function at  $-3$ , while keeping all the earlier open loop poles intact. Which one of the following is TRUE about the point where the root locus of the modified system transits to unstable region?

- (a) It corresponds to a frequency greater than  $K$
- (b) It corresponds to a frequency less than  $K$
- (c) It corresponds to a frequency  $K$
- (d) Root locus of modified system never transits to unstable region

Ans. (d)

End of Solution

**Q.55** The circuit shown in the figure has two sources connected in series. The instantaneous voltage of the AC source (in Volt) is given by  $v(t) = 12 \sin t$ . If the circuit is in steady state, then the rms value of the current (in Amperes) flowing in the circuit is \_\_\_\_\_.

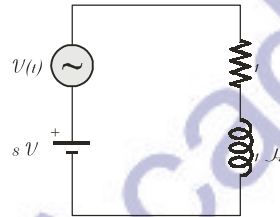

Ans. (10)

End of Solution