

Question Paper of Engineering Service Examination 2010 Electrical Engineering Paper-I

Objective

1.

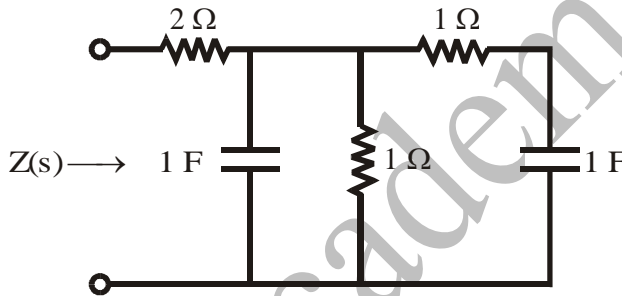

For the driving point impedance function, $Z(s) = \frac{as^2 + 7s + 3}{s^2 + 3s + b}$, the circuit

realization is shown above. The values of 'a' and 'b' respectively are

- | | |
|-------------|-------------|
| (a) 4 and 5 | (b) 2 and 5 |
| (c) 2 and 1 | (d) 2 and 3 |

2. Consider the following statements :

The A to D converter used in a digital instrument could be

1. Successive approximation converter type.
2. Flash converter type.
3. Dual slope converter type.

The correct sequence in the increasing order of the conversion time taken by these types is

- | | |
|----------------|----------------|
| (a) 1, 2 and 3 | (b) 2, 1 and 3 |
| (c) 1, 3 and 2 | (d) 2, 3 and 2 |

3. For photoconductors with equal electron and hole mobilities and perfect ohmic contacts at the ends, an increase in intensity of optical illumination results in

- (a) A change in open circuit voltage
- (b) A change in short circuit current
- (c) Decrease in resistance
- (d) Increase in resistance

4. Consider the following statements in connection with two-position controller :
1. If the controller has a 4% neutral zone, its positive error band will be 2% and negative error band will be 8%.
 2. The neutral zone is also known as dead band.
 3. The controller action of a two-position controller is very similar to that of a pure on-off controller.
 4. Air-conditioning system works essentially on a two-position control basis.

Which of the above statements are correct?

- (a) 1, 2 and 3 only (b) 2, 3 and 4 only
(c) 2 and 4 only (d) 1, 2, 3 and 4
5. For the following driving point impedance functions, which of the following statement true?

$$Z_1(s) = \frac{s+2}{s^2+3s+5}$$

$$Z_2(s) = \frac{s+2}{s^2+5}$$

$$Z_3(s) = \frac{s+3}{s^2+2s+1}$$

$$Z_4(s) = \frac{(s+2)(s+4)}{(s+1)(s+3)}$$

- (a) Z_1 is not positive real
(b) Z_2 is positive real
(c) Z_3 is positive real
(d) Z_4 is positive real
6. A piezoelectric crystal has a thickness of 2.5 mm and a voltage sensitivity of 0.05 Vm/N. The piezoelectric crystal is subjected to an external pressure of 1.6×10^6 N/m², then the corresponding output voltage is
- (a) 200 volts
(b) 3.2×10^{-9} volts/m of thickness
(c) 0.07×10^{-9} V/(m³/New)
(d) 200 m volts

7.

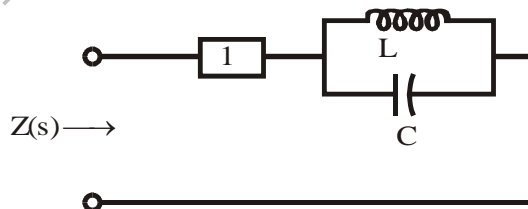

A reactance network in the Foster's I form has poles at $\omega = 0$ (zero) and $\omega = \infty$ (infinity). The element in box-1 in the above network is

- (a) A capacitor (b) A inductor
(c) A parallel LC circuit (d) A series LC circuit
8. The measurement of Hall coefficient of a semiconductor with one type of charge carrier gives the information about.
- (a) Sign of charge carrier

- (b) Density of charge carrier
 (c) Both sign and density of charge carrier
 (d) Mass of the charge carrier

9. Consider the following statements with reference to the phase plane :

- They are general and applicable to a system of any order.
- Steady state accuracy and existence of limit cycle can be predicted.
- Amplitude and frequency of limit cycle if exists can be evaluated.
- Can be applied to discontinuous time system.

Which of the above statements are correct?

- (a) 1, 2, 3 and 4
 (b) 2 and 3 only
 (c) 3 and 4 only
 (d) 2, 3 and 4 only

10. Consider the following units for the measurement of pressure directly :

- Rolta meter
- Bourdon tube
- Planti meter
- Vanes

Of these, the pressure can be measured by

- (a) 1 and 2 only
 (b) 3 and 4 only
 (c) 2 only
 (d) 1, 2, 3 and 4

11.

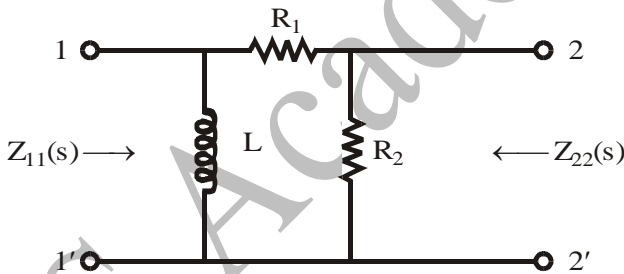

For the circuit shown above, the natural frequencies at port 2 are given by $s + 2 = 0$ and $s + 5 = 0$, without knowing which refers to open-circuit and which to short-circuit. Then the impedance Z_{11} and Z_{22} are given respectively by

- (a) $K_1 \frac{s+5}{s+2}$, $K_2 \frac{s+2}{s+5}$
 (b) $K_1 \frac{s+2}{s+5}$, $K_2 \frac{s+5}{s+2}$
 (c) $K_1 \frac{s}{s+5}$, $K_2 \frac{s+2}{s+5}$
 (d) $K_1 \frac{s+2}{s+5}$, $K_2 \frac{s+2}{s+5}$

12. If reflection coefficient for voltage be 0.6, the voltage standing wave ratio (VSWR) is

- (a) 0.66
 (b) 4
 (c) 1.5
 (d) 2

13. Consider the following statements :

Piezoelectric materials serve as

- A source of ultrasonic waves.
- When electric field is applied, the mechanical dimensions of the substances are not at all altered.
- Converts electrical energy to mechanical and vice versa.

4. Converts thermal energy to electrical energy.

Which of the above statements is/are correct?

- (a) 1 only (b) 2 and 3 only
(c) 1 and 3 only (d) 1, 2, 3 and 4

14. A two-port network is defined by the relation :

$$I_1 = 5 V_1 + 3 V_2$$

$$I_2 = 2 V_1 - 7 V_2$$

The value of Z_{12} is

- (a) 3 (b) -3
(c) $\frac{3}{41}$ (d) $\frac{2}{31}$

15. Consider the following statements :

- The main shortcomings of diaphragms are that they are prone to shock vibrations.
- Diaphragms have the advantages of high accuracy and good dynamic response.
- Selection of material for diaphragms mainly depends upon temperature range and chemical nature of fluid coming in contact with diaphragm during pressure measurement.

Which of the above statements is/are correct

- (a) 1, 2 and 3 (b) 2 and 3 only
(c) 1 only (d) 1 and 2 only

16. The Z-transform of $x(K)$ is given by

$$x(Z) = \frac{(1 - e^{-T})Z^{-1}}{(1 - Z^{-1})(1 - e^{-T}Z^{-1})}$$

The initial value $x(0)$ is

- (a) Zero (b) 1
(c) 2 (d) 3

17.

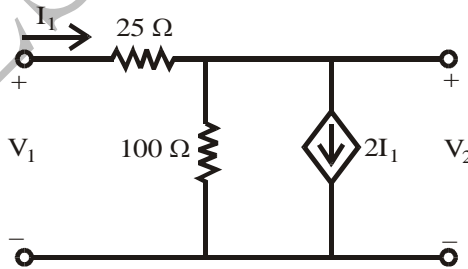

The Y-parameters of the network shown above are

- (a) $\begin{bmatrix} -0.04 & -0.04 \\ 0.04 & 0.03 \end{bmatrix}$ (b) $\begin{bmatrix} 0.04 & -0.04 \\ 0.04 & -0.03 \end{bmatrix}$
(c) $\begin{bmatrix} 0.04 & -0.03 \\ -0.04 & 0.03 \end{bmatrix}$ (d) $\begin{bmatrix} -0.04 & 0.03 \\ 0.04 & 0.03 \end{bmatrix}$

(δ) $\sigma^2 + \sigma + 2 = 0$

24. Consider the following statements :

The transfer impedances of a 2-port network remain constant when the position of excitation and response are interchanged if the network

1. Is linear.
2. Contains bilateral elements.
3. Has high impedance.
4. Is resonant.

Which of the above statements is/are correct?

- (a) 1 and 2 only (b) 1, 3 and 4 only
(c) 2 only (d) 1, 2, 3 and 4

25. When a ferromagnetic substance is magnetized, there are small changes in dimensions. The phenomenon is called

- (a) Hysteresis (b) Magnetostriction
(c) Diamagnetism (d) Dipolar relaxation

26. For a parallel RLC circuit, if $R = 40 \Omega$, $L = 2 \text{ H}$ and $C = 0.5 \text{ F}$, the bandwidth and quality factor are respectively

- (a) 20 rad/s, 0.05 (b) 10 rad/s, 20
(c) 20 rad/s, 10 (d) 0.05 rad/s, 20

27. Consider the following statements :

1. Electromagnetic flowmeter is independent of liquid density.
2. Electromagnetic flowmeter cannot be employed for measuring flow of non-conducting fluids.

Which of the above statements is/are correct?

- (a) 1 only (b) Both 1 and 2
(c) 2 only (d) Neither 1 nor 2

28. If a series RLC circuit resonates at 1.5 kHz and consumes 100 watts from a 100 volts a.c. source operating at resonant frequency with a bandwidth of 0.75 kHz; the values of R, L and Q-factor of the circuit are respectively.

- (a) 100Ω ; $\frac{0.2}{3\pi} \text{ H}$; 2 (b) 50Ω ; $\frac{0.1}{2\pi} \text{ H}$; 4
(c) 100Ω ; $\frac{2}{3\pi} \text{ H}$; 1 (d) 50Ω ; $\frac{0.3}{2\pi} \text{ H}$; 3

29. Consider the following statements :

1. The main drawback of digital system is that the real world is mainly analog.
2. The major advantage of digital instruments over analog instruments is higher accuracy and better resolution.
3. Digital instruments are ordinarily used for the measurement of both analog and digital quantities.

Which of the above statements is/are correct?

- (a) 1, 2, 3 and 4
(b) 1 and 3 only
(c) 2 only
(d) 1 and 2 only

30. For a parallel resonant circuit, if the damped frequency is $\sqrt{8}$ rad/s and the bandwidth is 2 rad/s, the resonant frequency of the circuit is

- (a) 10 rad/s (b) 7 rad/s

(c) 3 rad/s

(d) 2 rad/s

31. The resonant frequency of an RLC series circuit is 1.5 MHz with the resonating capacitor of 150 pF. The bandwidth is 10 kHz. The effective value of the resistor is

(a) 16.3 Ω (b) 9.5 Ω (c) 7.4 Ω (d) 4.7 Ω

32. A 4-digit DVM (digital voltmeter) with a 100-mV lowest full-scale range would have a sensitivity of how much value while resolution of this DVM is 0.0001 ?

(a) 0.1 mV

(b) 0.01 mV

(c) 1.0 mV

(d) 10 mV

33. For the network function,

$T(s) = \frac{s}{s^2 + 2s + 100}$, the resonant frequency and bandwidth are respectively

(a) 10, 1

(b) 10, 2

(c) 100, 1

(d) 100, 2

34. The state variable description of a linear autonomous system is $\dot{X} = AX$ where X is

a two-dimensional vector and A is a matrix given by $A = \begin{bmatrix} 0 & -2 \\ 2 & 0 \end{bmatrix}$. The poles of the system are located at

(a) -2 and +2

(b) $-j^2$ and $+j^2$

(c) -2 and -2

(d) +2 and +2

35.

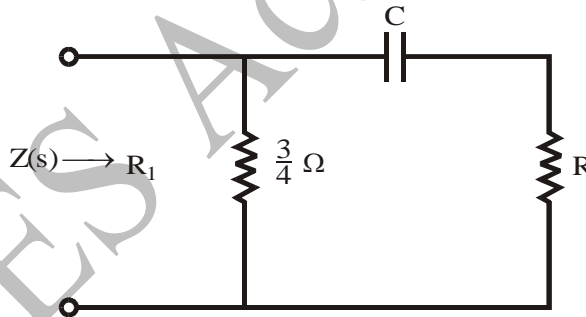

For the circuit shown above, the two natural frequencies of the driving-point impedance $Z(s)$ are given by $s + 1 = 0$ and $s + 4 = 0$. It is not known, which is for open-circuit and which is for short-circuit. Then $Z(s)$ is given by

(a) $\frac{3(s+4)}{16(s+1)}$ (b) $\frac{3(s+4)}{4(s+1)}$ (c) $3 \frac{(s+1)}{(s+4)}$ (d) $\frac{1}{3} \frac{(s+4)}{(s+1)}$

36. Match List I with List II and select the correct answer using the code given below the lists:

List I

(Meter)

- A. Reed frequency meter
 B. Weston frequency meter
 C. Weston Synchroscope
 D. Ohm meter

List II

(Type)

1. Moving iron
 2. Vibrating
 3. Moving coil
 4. Electro-dynamic

Codes :

- | | A | B | C | D |
|-----|---|---|---|---|
| (a) | 2 | 1 | 4 | 3 |
| (b) | 3 | 1 | 4 | 2 |
| (c) | 2 | 3 | 4 | 1 |
| (d) | 3 | 4 | 1 | 2 |

37. A transfer function has a zero at $s = -1$ and poles at $s = -1, \pm j1$. The multiplier being unity, if the input is unit step function, the steady state response is given by

- (a) $0.5 \angle 0^\circ$ (b) $1.0 \angle 0^\circ$
 (c) $2.0 \angle 0^\circ$ (d) $2.0 \angle 90^\circ$

38. Match List I with List II and select the correct answer using the code given below the lists:

List I

- A. Ferro-electric materials
 B. Anti-Ferroelectric materials
 C. Ferrites
 D. Ferro-magnetic materials

List II

1. Neel temperature
 2. Magnetostrictive transducers
 3. Magnetocaloric effect
 4. Cannot be shaped by ordinary machining process

Codes :

- | | A | B | C | D |
|-----|---|---|---|---|
| (a) | 2 | 4 | 1 | 3 |
| (b) | 3 | 4 | 1 | 2 |
| (c) | 2 | 1 | 4 | 3 |
| (d) | 3 | 1 | 4 | 2 |

39.

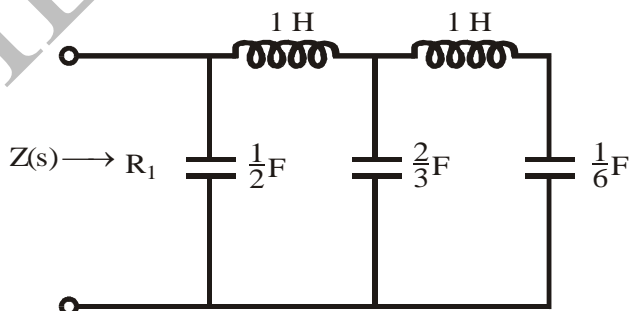

For the circuit shown, the values of $Z(s)$ as $s \rightarrow 0$ and $s \rightarrow \infty$ respectively given by

- (a) $\frac{2}{s}, s$ (b) $\frac{6}{8s}, \frac{2}{s}$
 (c) $\frac{8s}{6}, \frac{s}{2}$ (d) $4s + \frac{6}{s}, \frac{2}{s}$

40. The precision of a ramp type digital voltmeter depends on
- Frequency of the generator and slope of the ramp
 - Frequency of the generator
 - Slope of the ramp
 - Switching time of the gate
41. The transfer functions of a phase-lead compensator is given by $G(s) = \frac{1 + 3Ts}{1 + Ts}$, $T > 0$. The maximum phase shift provided by such a compensator is
- 90°
 - 60°
 - 45°
 - 30°
42. Match List I with List II and select the correct answer using the code given below the lists:
- | List I | List II |
|--|----------------------------|
| A. Iron loss of a choke carrying a.c. current at 50 Hz along with d.c. | 1. Electrostatic wattmeter |
| B. Calibration of a dynamometer Type wattmeter | 2. Oscilloscope |
| C. Dielectric loss of a capacitor at 20 Hz | 3. D.C. Potentiometer |
| D. Power loss of an insulator testing at high voltages | 4. A.C. Potentiometer |
- Codes :
- | | A | B | C | D |
|-----|---|---|---|---|
| (a) | 3 | 1 | 4 | 2 |
| (b) | 2 | 1 | 4 | 3 |
| (c) | 3 | 4 | 1 | 2 |
| (d) | 2 | 4 | 1 | 3 |
43. If the initial voltage across the capacitor of 2 Farad is $V(0) = 1$, the voltage and charge on the capacitor at $t = 3$ sec after connecting a current source $I_s = 2$ A at $t = 0$ are respectively
- 2 V, 4 coulomb
 - 2 V, 4 coulomb
 - 4 V, 8 coulomb
 - 8 V, 4 coulomb
44. Consider the following statements :
- The coercive force can be increased by
- Adding Cobalt because it is a ferromagnetic material.
 - Adding Gold because it is a diamagnetic material.
 - Adding Super alloy.
 - Space charge polarizing.
- Which of the above statements is/are correct?
- 1, 2, 3 and 4
 - 1 only
 - 2 only
 - 1 and 3 only
45. If the load impedance is 100 ohm and input impedance is 25 ohm, then the characteristic impedance of the transmission line is
- 70 ohm
 - 60 ohm
 - 50 ohm
 - 40 ohm
46. Temperature below which certain materials are anti-ferromagnetic is called
- Curie temperature
 - Neel temperature

(c) Wein temperature

(d) Debye temperature

47. Consider the following statements :

A step voltage is applied to an under-damped series RLC circuit in which R is variable. If R is

1. Increased, the steady-state voltage across C will be reduced.
2. Increased, the frequency of transient oscillations across C will be reduced.
3. Reduced, the transient oscillation will die down at a fast rate.
4. Reduced to zero, the peak amplitude of the voltage across C will be double that of input voltage.

Which of the above statements is/are correct?

(a) 2 only

(b) 4 only

(c) 2 and 4 only

(d) 1, 2, 3 and 4

48. A moving coil ammeter having a resistance of 1 ohm gives full scale deflection when a current of 10 mA is passed through it. The instrument can be used for the measurement of voltage up to 10 V by

- (a) Connecting a resistance of 999 ohm in series with the instrument
- (b) Connecting a resistance of 999 ohm parallel to the ammeter
- (c) Connecting a resistance of 999 ohm parallel to the load
- (d) Connecting a resistance of 1000 ohm in series with the load

49.

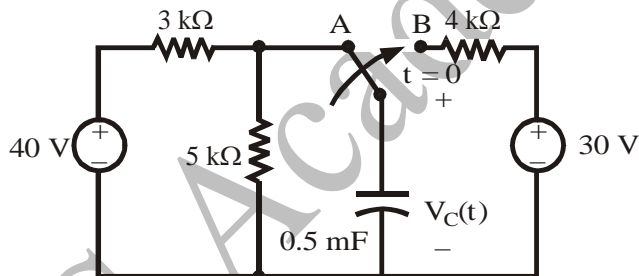

For the circuit shown above, the switch has been in position A for a long time. At $t = 0$, the switch is moved to B. Then, the capacitor voltage $V_C(t)$ for $t > 0$ is

(a) $V_C(t) = (24 - 6 e^{-2t})$ V(b) $V_C(t) = (30 - 15 e^{-0.5t})$ V(c) $V_C(t) = (6 - 6 e^{-2t})$ V(d) $V_C(t) = (30 - 5 e^{-0.5t})$ V

50. Consider the following statements :

Electrets are the materials which are

1. Having permanent electric moments.
2. Electromagnets.
3. Very similar to permanent magnet materials.
4. Similar to anti-ferroelectric materials.

Which of the above statements is/are correct?

(a) 2 only

(b) 1 and 3 only

(c) 2 and 3 only

(d) 1, 2, 3 and 4

51. Consider the following statements :

Magnetic susceptibility

1. Depends on the nature of the magnetic material.
2. Is not dependent on the relative permeability of the medium.
3. Cannot be determined by measuring the force exerted on a magnetic material when placed in a magnetic field.

4. Can be determined from $M - H$ curve.

Which of the above statements is/are correct?

- (a) 1, 2, 3 only
(b) 1 only
(c) 1 and 4 only
(d) 2 only

52. For a series RLC circuit energized with a sinusoidal voltage source of frequency 4 rad/s, the applied voltage lags the current by an angle of $\tan^{-1} 2$ degrees. Then the value of R for $L = 1$ H and $C = 0.05$ F is

- (a) 4.0 ohm
(b) 2.0 ohm
(c) 1.0 ohm
(d) 0.5 ohm

53.

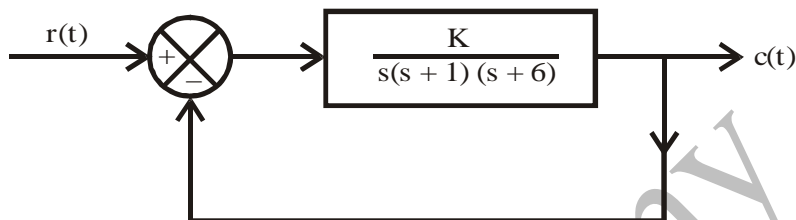

The feedback system shown above is stable for all values of K given by

- (a) $K > 0$
(b) $K < 0$
(c) $0 < K < 42$
(d) $0 < K < 60$

54. The value of the multiplier resistance for a dc voltmeter, having 50 V range with 5 k Ω /V sensitivity, employing a 200 μ A meter movement and having internal resistance of 100 Ω , is given by

- (a) 249.9 k Ω
(b) 200 Ω
(c) 200 k Ω
(d) 2.5 k Ω

55.

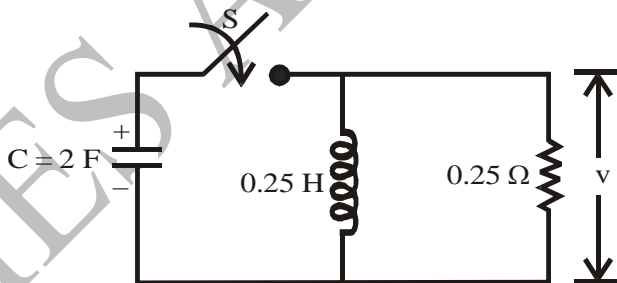

For the given circuit, the initial inductor current and the voltage across the capacitor are zero and 2, respectively. When the switch S is closed at $t = 0$, the

values of v and $\frac{dv}{dt}$ are, respectively

- (a) 2, -4
(b) 0, 0.25
(c) 0, -0.5
(d) 2, 0

56. Match List I with List II and select the correct answer using the code given below the lists:

List I

- A. Enamel covering
B. Insulation
C. Fibrous materials
D. Empire cloth

List II

1. Laminations
2. Wires
3. Machines
4. Transformers

Codes :

	A	B	C	D
(a)	2	4	1	3
(b)	3	4	1	2
(c)	2	1	4	3
(d)	3	1	4	2

57. For an a.c. circuit, if $v(t) = 160 \sin(\omega t + 10^\circ)$ and $i(t) = 5 \sin(\omega t - 20^\circ)$, the reactive power absorbed by the circuit is

- (a) 100 VARs (b) 200 VARs
(c) 300 VARs (d) 400 VARs

58. A signal of 10 V is applied to a 50 ohm coaxial transmission line, terminated in a 100 ohm load. The voltage reflection coefficient is

- (a) $\frac{1}{4}$ (b) $\frac{1}{3}$
(c) $\frac{1}{2}$ (d) 1

59. Consider the following statements :

Factors affecting the dielectric loss are

1. Directly proportional to the frequency of supply voltage.
2. Inversely proportional to the supply frequency.
3. Inversely proportional to the square of the supply voltage.
4. Directly proportional to the square of the supply voltage.

Which of the above statements are correct?

- (a) 1 and 3 only (b) 2 and 3 only
(c) 2 and 4 only (d) 1 and 4 only

60. A conductor 2 metre long lies along the Z-axis with a current of 10 A in \hat{a}_z direction. If the magnetic field is $\vec{B} = 0.05 \hat{a}_x$ T, the force on the conductor is

- (a) $4.0 \hat{a}_y$ N (b) $1.0 \hat{a}_z$ N
(c) $1.0 \hat{a}_y$ N (d) $3.0 \hat{a}_z$ N

61. Using Routh's criterion, the number of roots in the right half S-plane for the characteristic equation : $S^4 + 2s^3 + 2s^2 + 3s + 6 = 0$ is

- (a) One (b) Two
(c) Three (d) Four

62. Match List I with List II and select the correct answer using the code given below the lists:

List I

- A. Electrostatic
B. Induction
C. Dynamometer
D. Thermal

List II

1. Power at 50 Hz only
2. Power at frequencies ranging from dc to RF
3. Power at unity power factor and at high values
4. Power at frequencies ranging from dc 150 Hz

Codes :

	A	B	C	D
(a)	3	1	4	2
(b)	2	1	4	3

- (c) 3 4 1 2
 (d) 2 4 1 3

63.

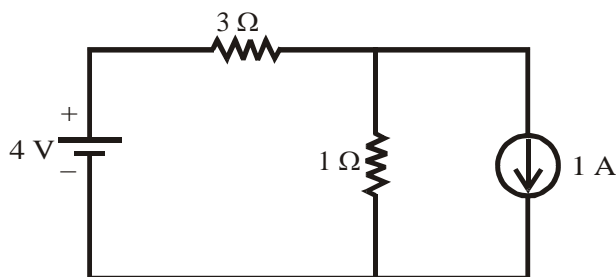

For the circuit shown, the voltage across the 1 ohm resistor is given by

- (a) $\frac{7}{4}$ V (b) $\frac{5}{4}$ V
 (c) $\frac{7}{3}$ V (d) $\frac{2}{3}$ V

64. Consider the following statements :

Characteristics of a good insulating material are

1. Should give uniform electric and thermal properties.
2. High permittivity.
3. Low dissipation factor.
4. Low insulating resistance.

Which of the above statements are correct?

- (a) 1 and 4 only (b) 2 and 4 only
 (c) 1 and 3 only (d) 1, 2, 3 and 4

65. At a measuring frequency of 10^{12} Hz, the dielectric constant of a material will be due to

- (a) Electronic polarization
 (b) Ionic polarization
 (c) Electronic and Ionic polarization
 (d) Electronic, Ionic and Orientational polarization

66. A load is connected to an active network. At the terminals to which the load is connected, $R_{th} = 10 \Omega$ and $V_{th} = 60$ V. Then the maximum power supplied to the load is

- (a) 360 W (b) 90 W
 (c) 60 W (d) 10 W

67. A basic D' Arsonval movement with a full scale deflection of $50 \mu\text{A}$ and internal resistance of 500Ω is used as voltmeter. The value of the multiplier resistance needed to employ this meter to measure a voltage range of $(0 - 10)$ V is given by

- (a) 100 k Ω (b) 500 k Ω
 (c) 199.5 k Ω (d) 2×10^5 k Ω

68. The feedback control system represented by the open loop transfer function

$$G(s)H(s) = \frac{10(s+2)}{[(s+1)(s+3)(s-5)]}$$
 is

- (a) Unstable (b) Stable
 (c) Marginally stable (d) Insufficient stable

69. Consider the following statements regarding measurement of 3-phase power by two-wattmeter method; one of the wattmeter reads negative implying :
1. Power factor is less than 0.5.
 2. Power flow is in the reverse direction.
 3. Load power factor angle is greater than 60° .
 4. Load is unbalanced

Which of the above statements are correct?

- (a) 1 and 2 only (b) 2 and 3 only
(c) 1 and 3 only (d) 1, 2, 3 and 4
- 70.

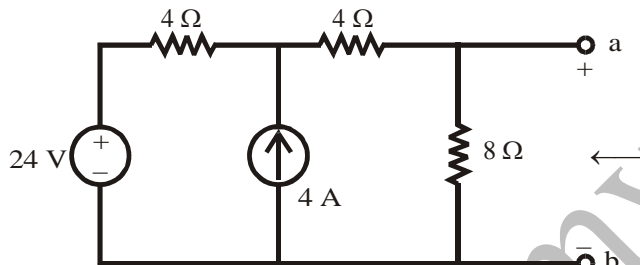

Applying Norton's Theorem, the Norton's equivalent circuit to the left of the terminals a and b in the above circuit is having equivalent current source (I_N) and equivalent resistance (R_N) as

- (a) $I_N = 5\text{ A}; R_N = 4\ \Omega$ (b) $I_N = 4\text{ A}; R_N = 6\ \Omega$
(c) $I_N = 9\text{ A}; R_N = 1.6\ \Omega$ (d) $I_N = 4\text{ A}; R_N = 3\ \Omega$
71. The property characteristic of ferroelectric materials is
- (a) Dielectric relaxation
 - (b) Dielectric breakdown
 - (c) Spontaneous polarization
 - (d) Spontaneous magnetization
72. A uniform plane wave is propagating in a material for which $\epsilon = 4\epsilon_0$, $\mu = 7\mu_0$ and $\sigma = 0$. The skin depth for the material is
- (a) Zero
 - (b) Infinity
 - (c) 28 m
 - (d) 14 m
73. Consider the following statements about superconductors :

1. The temperature at which the conductor becomes a superconductor is called transition temperature.
2. Superconductors repel magnetic flux lines.
3. All superconductors are paramagnetic materials.
4. Superconductors become normal when placed in a magnetic field of certain critical value.

Which of the above statements are correct?

- (a) 1 and 2 only (b) 2 and 4 only
(c) 1, 2 and 4 only (d) 1, 2, 3 and 4
74. Consider the following statements in connection with the closed-loop poles of feedback control system :
1. Poles on $j\omega$ -axis will make the output amplitude neither decaying nor growing in time.
 2. Dominant closed-loop poles occur in the form of a complex conjugate pair.

3. The gain of a higher order system is adjusted so that there will exist a pair of complex conjugate closed-loop poles on $j\omega$ -axis.
4. The presence of complex conjugate closed-loop poles reduces the effects of such non-linearities as dead zones, backlash and coulomb friction.

Which of the above statements is/are correct?

- (a) 2 only (b) 2, 3 and 4 only
(c) 1, 2 and 4 only (d) 1, 2, 3 and 4
75. The sensitivity of 200 μA meter movement when it is used as a dc voltmeter is given by
(a) 500 Ω/mV (b) 5 Ω/mV
(c) 0.5 Ω/mV (d) 5 Ω/mV

76. Consider a unity feedback control system with open-loop transfer function

$G(s) = \frac{K(s+1)}{s(s+2)(s+3)}$. The steady-state error of the system due to a unit step input is

- (a) Zero (b) $\frac{K}{6}$
(c) $\frac{6}{K}$ (d) Infinite
77. A 1 mA meter movement with an internal resistance of 100 Ω is to be converted into (0 – 100) mA. To achieve this, value of shunt resistance R_{sh} is given by
(a) 1 k Ω (b) 200 Ω
(c) 1.01 Ω (d) 1.01 k Ω

78.

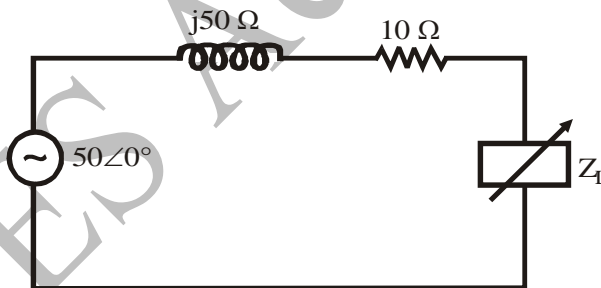

The maximum power that can be transferred in the load Z_L in the above circuit is

- (a) 12.25 W (b) 62.5 W
(c) 24.5 W (d) 500 W
79. Match List I with List II and select the correct answer using the code given below the lists:

List I

- A. Precision work
B. Rheostat
C. Heating devices
D. Brushes

List II

1. Graphite
2. Nichrome
3. Constantan
4. Magnesium

Codes :

- | | A | B | C | D |
|-----|---|---|---|---|
| (a) | 4 | 3 | 2 | 1 |
| (b) | 1 | 3 | 2 | 4 |

- (c) 4 2 3 1
 (d) 1 2 3 4

80. Consider the following statements :

1. In conducting medium the field attenuates exponentially with increasing depth.
2. Conducting medium behaves like an open circuit to the electromagnetic field.
3. In lossless dielectric relaxation time is infinite.
4. In charge-free region, the Poisson's equation becomes Laplace's equation.

Which of the above statements are correct?

- (a) 1, 2 and 3 only
 (b) 1, 3 and 4 only
 (c) 2, 3 and 4 only
 (d) 1, 2, 3 and 4

81. In a Hexagonal Close Packed (HCP) crystal structure, if 'a' and 'c' represent, respectively the short and long unit cell dimensions the $\left(\frac{c}{a}\right)$ ratio should be

- (a) 12.00 (b) 0.74
 (c) 1.633 (d) 16.33

82.

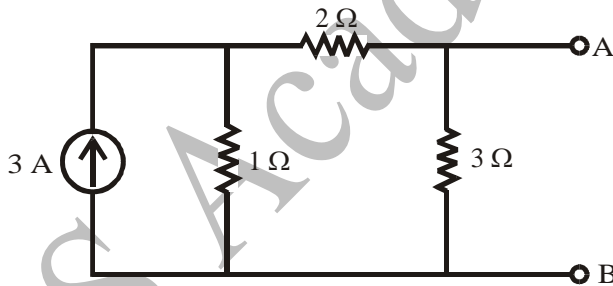

The Thevenin's equivalent of the circuit shown above is

- (a) 0.75 V, 1.5 Ω (b) 1.5 V, 1.5 Ω
 (c) 1.5 V, 0.75 Ω (d) 5.0 V, 1.5 Ω

83. Consider the following statements about hot-wire instruments :

1. They read equally well on dc and/or ac circuits.
2. They are simple and robust in construction and power consumption is low.
3. They are quite suitable for measurement of currents at very high frequencies.

Which of the above statements are correct?

- (a) 1 and 2 only
 (b) 2 and 3 only
 (c) 1 and 3 only
 (d) 1, 2, 3 and 4

84.

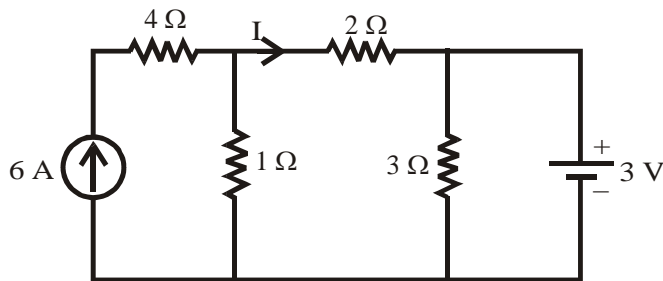

For the circuit shown above, I is

- (a) 0 A (b) 1 A
(c) 2 A (d) 3 A

85. A semiconductor has a band gap of 2 eV. The wavelength of radiation emitted from the semiconductor when electrons and holes recombine is

- (a) 625 nm (b) 625 μm
(c) 625 mm (d) 625 cm

86. In free space

$\vec{E}(Z, t) = 60 \pi \cos(\omega t - \beta Z) \bar{a}_x \text{ V/m}$. The average power crossing a circular area of π square metres in the plane $Z = \text{constant}$ is

- (a) $16 \pi \text{ watts/m}^2$
(b) $15 \pi \text{ watts/m}^2$
(c) $14 \pi \text{ watts/m}^2$
(d) $13 \pi \text{ watts/m}^2$

87. Match List I with List II and select the correct answer using the code given below the lists:

List I

- A. Metals
B. Semiconductors
C. Insulators
D. Ferroelectric crystals

List II

1. Are in spontaneously polarized state
2. Finite forbidden gap
3. Smaller forbidden gap
4. Partially filled bands

Code :

- | | A | B | C | D |
|-----|---|---|---|---|
| (a) | 4 | 3 | 2 | 1 |
| (b) | 1 | 3 | 2 | 4 |
| (c) | 4 | 2 | 3 | 1 |
| (d) | 1 | 2 | 3 | 4 |

88.

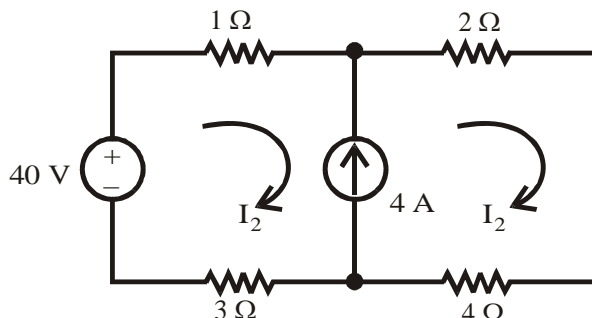

The currents I_1 and I_2 in the above circuit are respectively.

- (a) 4 A ; 4 A
 (b) 3 A ; 5A
 (c) 2 A ; 6 A
 (d) 6 A; 2A

89. A(0 – 25) Amp ammeter has a guaranteed accuracy of 1 percent of full scale reading. The current measured by this ammeter is 10 Amp. The limiting error in percentage for this instrument is

- (a) 2.5%
 (b) 0.5%
 (c) 0.25%
 (d) 0.025%

90. Given a unity feedback system with $G(s) = \frac{K}{s(s+4)}$, the value of K for damping ratio of 0.5 is

- (a) 1
 (b) 16
 (c) 4
 (d) 2

91. The pressure in a tank varies from 20 psi to 100 psi. Further pressure in the tank is desired to be kept at 50 psi. The full scale error, when pressure inside the tank is 30 psi, is given by

- (a) -62.5%
 (b) 25%
 (c) 80%
 (d) -2.5%

92.

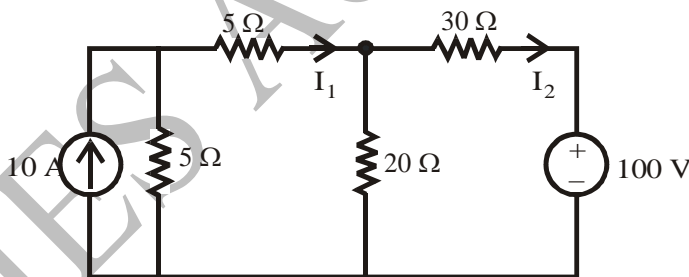

The currents I_1 and I_2 in the above circuit are respectively

- (a) 1.818 A; - 0.4545 A
 (b) 2.451 A; - 1.568 A
 (c) 0.4545 A; - 1.818 A
 (d) 1.56 A; - 2.45 A

93. The following data are obtained by measurement on gold :

Density = 19.32 gm/cc

Resistivity = 2.42 $\mu\Omega/cm$

Atomic weight = 197.2

The mobility of electrons in gold is

- (a) $4.39 \times 10^{-3} m^2/V\text{-sec}$
 (b) $4.39 \times 10^{-2} m^2/V\text{-sec}$
 (c) $4.39 m^2/V\text{-sec}$
 (d) $4.39 \times 10^3 m^2/V\text{-sec}$

94. A magnetic field \vec{B} of 2 T is normal to a copper strip 0.5 mm thick carrying an electron current of 40 A. If the electron density is 10.0×10^{28} per cubic metre, the voltage across the strip in micro volt is

- (a) 40
(c) 20

- (b) 30
(d) 10

95. Match List I with List II and select the correct answer using the code given below the lists:

List I

- A. High conductivity materials
B. High resistivity materials
C. Metals for lightly loaded contacts
D. Materials for bimetallic strip

List II

1. Tungsten, Carbon
2. Platinum, Molybdenum
3. Aluminium, Copper
4. Iron, Nickel, Constantan

Code :

- | | A | B | C | D |
|-----|---|---|---|---|
| (a) | 3 | 1 | 2 | 4 |
| (b) | 4 | 1 | 2 | 3 |
| (c) | 3 | 2 | 1 | 4 |
| (d) | 4 | 2 | 1 | 3 |

- 96.

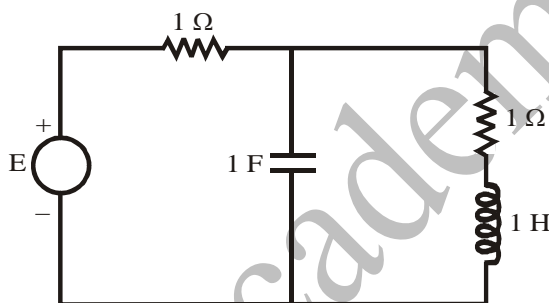

If the power dissipated in the circuit shown above is 8 W, then the value of E will be

- (a) 2 V
(c) 8 V
(b) 4 V
(d) 16 V

97. A resistance of 105 ohms is specified using significant figures as indicated below :

1. 105 ohms
2. 105.0 ohms
3. 0.000105 $\mu\Omega$

Among these

- (a) 1 represents greater precision than 2 and 3.
(b) 2 and 3 represent greater precision than 1.
(c) 1, 2 and 3 represent same precision.
(d) 2 represents greater precision but 1 and 3 represent same precision.

98. Consider the following statements in connection with pole location :

1. A distinct pole always lies on the real axis.
2. A dominant pole has a large time constant.

Which of the above statements is/are correct?

- (a) Both 1 and 2
(c) 1 only
(b) Neither 1 nor 2
(d) 2 only

99. A (0 – 250) V voltmeter has a guaranteed accuracy of 2 percent of full scale reading. The voltage measured by this voltmeter is 150 volts. The limiting error in percentage is

- (a) 2.5%
(b) 0.05%

(c) 3.33%

(d) 5.0%

100.

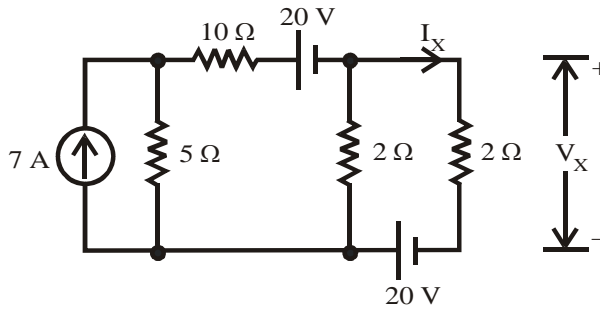

The current I_x and voltage V_x in the above circuit are, respectively

(a) 5 A; 10 V

(b) 10 A; 20 V

(c) 6 A; 12 V

(d) 4 A; 8 V

101. Consider the following statements :

Secondary (or Molecular) bonds are

1. The attraction forces exist between atoms or molecules.
2. Stronger than primary bonds.
3. Can be divided as electrostatic bonds.
4. Weaker than primary bonds.

Which of the above statements is/are correct?

(a) 1 only

(b) 2 and 3 only

(c) 1 and 4 only

(d) 1, 2, 3 and 4

102. Point charges of $Q_1 = 2 \text{ nC}$ and $Q_2 = 3 \text{ nC}$ are located at a distance apart. With regard to this situation, which one of the following statements is *not* correct?

- (a) The force on the 3 nC charge is repulsive.
- (b) A change of -5 nC placed midway between Q_1 and Q_2 will experience no force.
- (c) The forces Q_1 and Q_2 are same in magnitude.
- (d) The forces on Q_1 and Q_2 will depend on the medium in which they are placed.

103. Consider the following statements referring to the magnetization :

1. In solenoid magnetization is due to a surface current distribution.
2. Magnetization has its origin in circulating current.
3. The solenoid dipole is represented by an infinitesimal current loop.
4. The magnetization is entirely solenoidal and divergent

Which of the above statements is/are correct?

(a) 1, 2 and 3 only

(b) 2, 3 and 4 only

(c) 3 only

(d) 1, 2, 3 and 4

104. Increase in the applied reverse voltage to a p-n junction results in increase in the

- (a) Depletion width
- (b) Barrier height
- (c) Depletion width and barrier height
- (d) Junction temperature

105.

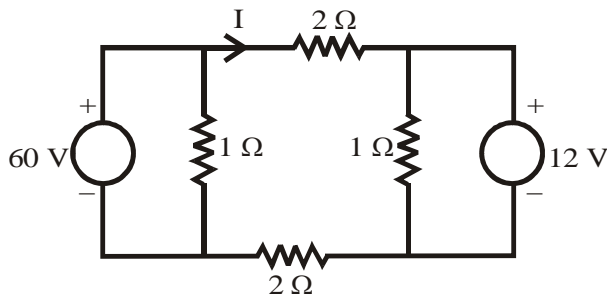

For the circuit shown, the value of current, I is

- (a) 2 A (b) 3 A
(c) 6 A (d) 12 A

106. Consider the following statements with regard to manufacture of a standard resistor :

1. The material should be of high resistivity and low temperature coefficient.
2. Resistors are shielded against magnetic field.
3. Nickel-chromium is best suited for resistance of high value.

Which of the above statements is/are correct?

- (a) 1 and 2 only (b) 1 only
(c) 1 and 3 only (d) 3 only

107. Consider the following statements in connection with the feedback of control systems :

1. Feedback can improve stability or be harmful to stability if it not properly applied.
2. Feedback can always improve stability.
3. In many situations the feedback can reduce the effect of noise and disturbance on system performance.
4. In general the sensitivity of the system gain of a feedback system to a parameter variation depends on where the parameter is located.

Which of the above statements are correct?

- (a) 1, 2 and 3 only (b) 1, 3 and 4 only
(c) 1, 2 and 4 only (d) 1, 2, 3 and 4

Directions : Each of the next thirteen (13) items consists of two statements, one labeled as the 'Assertion (A)' and the other as 'Reason (R)'. You are to examine these two statements carefully and select the answers to these items using the codes given below :

Codes :

- (a) Both A and R are individually true and R is the correct explanation of A
(b) Both A and R are individually true but R is *not* the correct explanation of A
(c) A is true but R is false
(d) A is false but R is true

108. **Assertion (A) :** A thin sheet of conducting material can act as a low-pass filter for electromagnetic waves.

Reason (R) : The depth of penetration is inversely proportional is inversely proportional to the square root of the frequency.

109. **Assertion (A) :** Piezoelectric transducers can be used for measurement of both static and dynamic phenomena.

Reason (R) : Piezoelectric transducers have very good high frequency response.

110. **Assertion (A)** : Ionic bonds and covalent bonds are higher than metallic bonds.
Reason (R) : Ionic and covalent bonds are generally lower than other primary bonds.
111. **Assertion (A)** : The effects of noise disturbance and parameter variations are relatively easy to visualize and access through frequency response.
Reason (R) : Frequency response test is suitable for systems with very large time constants.
112. **Assertion (A)** : All the coefficients of the characteristic equation should be positive and no term should be missing in the characteristic equation for a system to be stable.
Reason (R) : If some of the coefficients are zero or negative then the system is not stable.
113. **Assertion (A)** : Process industry applications should ideally be tuned for critical damping.
Reason (R) : Critically damped response has no oscillations in the output.
114. **Assertion** : Intrinsic semiconductors show negative Hall coefficient.
Reason (R) : The number of electrons and holes are equal in an intrinsic semiconductor.
115. **Assertion (A)** : A thermocouple type of indicating instrument measures the true r.m.s. value of the current that passes through it.
Reason (R) : It uses a p.m.m.c. type of indicating instrument to measure the current.
116. **Assertion (A)** : Magnetic cores are generally used in main memory of a digital computer.
Reason (R) : Magnetic cores are slow and volatile.
117. **Assertion (A)** : Comparison methods of direct measurements are most widely used in electrical engineering practice.
Reason (R) : Comparison methods of direct measurements give high accuracy.
118. **Assertion (A)** : The Q-meter measure the Q-factor of a coil when the circuit is in resonance.
Reason (R) : The Q-factor of a coil depends only on its inductance and not on its resistance.
119. **Assertion (A)** : The spins within a magnetic domain are aligned permanently below Curie temperature in a ferromagnetic material.
Reason (R) : Ferromagnetic material is magnetic only when the domains are aligned by an external field.
120. **Assertion (A)** : Bellows are quite suitable for dynamic pressure measurements.
Reason (R) : Bellows are rugged, simple and rugged in construction and are capable of providing large force and wide pressure range of measurements.